



**OWNER'S MANUAL**



***XF50E***

**15P-F8199-E0**



# INTRODUCTION

---

EAU10110

Welcome to the Yamaha world of motorcycling!

As the owner of the XF50E, you are benefiting from Yamaha's vast experience and newest technology regarding the design and manufacture of high-quality products, which have earned Yamaha a reputation for dependability.

Please take the time to read this manual thoroughly, so as to enjoy all advantages of your XF50E. The owner's manual does not only instruct you in how to operate, inspect and maintain your scooter, but also in how to safeguard yourself and others from trouble and injury.

In addition, the many tips given in this manual will help keep your scooter in the best possible condition. If you have any further questions, do not hesitate to contact your Yamaha dealer.

The Yamaha team wishes you many safe and pleasant rides. So, remember to put safety first!

# **IMPORTANT MANUAL INFORMATION**

---

EAU34111

Particularly important information is distinguished in this manual by the following notations:



**The Safety Alert Symbol means ATTENTION! BECOME ALERT! YOUR SAFETY IS INVOLVED!**



**Failure to follow WARNING instructions could result in severe injury or death to the scooter operator, a bystander, or a person inspecting or repairing the scooter.**

**CAUTION:**

**A CAUTION indicates special precautions that must be taken to avoid damage to the scooter.**

**NOTE:**

A NOTE provides key information to make procedures easier or clearer.

**NOTE:**

- This manual should be considered a permanent part of this scooter and should remain with it even if the scooter is subsequently sold.
- Yamaha continually seeks advancements in product design and quality. Therefore, while this manual contains the most current product information available at the time of printing, there may be minor discrepancies between your scooter and this manual. If you have any questions concerning this manual, please consult your Yamaha dealer.

EWA12410



**PLEASE READ THIS MANUAL CAREFULLY AND COMPLETELY BEFORE OPERATING THIS SCOOTER.**

---

\*Product and specifications are subject to change without notice.

# **IMPORTANT MANUAL INFORMATION**

---

EAUT1390

**XF50E  
OWNER'S MANUAL  
©2007 by Yamaha Motor Taiwan Co., Ltd.  
1st edition, July 2007  
All rights reserved.  
Any reprinting or unauthorized use  
without the written permission of  
Yamaha Motor Taiwan Co., Ltd.  
is expressly prohibited.  
Printed in Taiwan.**

# TABLE OF CONTENTS

---

<b>SAFETY INFORMATION</b> .....	1-1
Further safe-riding points .....	1-4

<b>DESCRIPTION</b> .....	2-1
Left view .....	2-1
Right view .....	2-2
Controls and instruments .....	2-3

<b>INSTRUMENT AND CONTROL FUNCTIONS</b> .....	3-1
Main switch/steering lock .....	3-1
Keyhole cover .....	3-2
Indicator and warning lights .....	3-2
Speedometer unit .....	3-4
Fuel gauge .....	3-4
Handlebar switches .....	3-5
Front brake lever .....	3-6
Rear brake lever .....	3-6
Fuel tank cap .....	3-6
Fuel .....	3-7
Catalytic converter .....	3-8
Kickstarter .....	3-8
Seat .....	3-9
Luggage hook .....	3-9
Helmet holder .....	3-9
Storage compartment .....	3-10

<b>PRE-OPERATION CHECKS</b> .....	4-1
Pre-operation check list .....	4-2

<b>OPERATION AND IMPORTANT RIDING POINTS</b> .....	5-1
Starting the engine .....	5-1
Starting off .....	5-2
Acceleration and deceleration .....	5-2
Braking .....	5-2
Engine break-in .....	5-3
Parking .....	5-3

<b>PERIODIC MAINTENANCE AND MINOR REPAIR</b> .....	6-1
Periodic maintenance and lubrication chart .....	6-2
Removing and installing panels .....	6-5
Checking the spark plug .....	6-6
Engine oil and oil strainer .....	6-7
Final transmission oil .....	6-9
Coolant .....	6-10
Replacing the air filter element .....	6-12
Checking the throttle cable free play .....	6-12
Valve clearance .....	6-12
Tires .....	6-13
Cast wheels .....	6-15
Adjusting the brake lever free play .....	6-15
Adjusting the rear brake lever free play .....	6-16
Checking the front and rear brake shoes .....	6-16

Checking and lubricating the throttle grip and cable .....	6-17
Lubricating the front and rear brake levers .....	6-17
Checking and lubricating the centerstand .....	6-18
Checking the front fork .....	6-18
Checking the steering .....	6-19
Checking the wheel bearings .....	6-19
Battery .....	6-20
Replacing the fuse .....	6-21
Replacing the headlight bulb .....	6-22
Replacing the tail/brake light bulb .....	6-23
Replacing a turn signal light bulb .....	6-24
Troubleshooting .....	6-24
Troubleshooting charts .....	6-25

<b>SCOOTER CARE AND STORAGE</b> ...	7-1
Care .....	7-1
Storage .....	7-3

<b>SPECIFICATIONS</b> .....	8-1
-----------------------------	-----

<b>CONSUMER INFORMATION</b> .....	9-1
Identification numbers .....	9-1

# **TABLE OF CONTENTS**

# SAFETY INFORMATION

---

EAU10261

SCOOTERS ARE SINGLE TRACK VEHICLES. THEIR SAFE USE AND OPERATION ARE DEPENDENT UPON THE USE OF PROPER RIDING TECHNIQUES AS WELL AS THE EXPERIENCE OF THE OPERATOR. EVERY OPERATOR SHOULD KNOW THE FOLLOWING REQUIREMENTS BEFORE RIDING THIS SCOOTER.

HE OR SHE SHOULD:

- OBTAIN THOROUGH INSTRUCTIONS FROM A COMPETENT SOURCE ON ALL ASPECTS OF SCOOTER OPERATION.
- OBSERVE THE WARNINGS AND MAINTENANCE REQUIREMENTS IN THE OWNER'S MANUAL.
- OBTAIN QUALIFIED TRAINING IN SAFE AND PROPER RIDING TECHNIQUES.
- OBTAIN PROFESSIONAL TECHNICAL SERVICE AS INDICATED BY THE OWNER'S MANUAL AND/OR WHEN MADE NECESSARY BY MECHANICAL CONDITIONS.

## Safe riding

- Always make pre-operation checks. Careful checks may help prevent an accident.
- This scooter is designed to carry the operator and passenger.
- The failure of motorists to detect and recognize scooters in traffic is the predominating cause of automobile/scooter accidents. Many accidents have been caused by an automobile driver who did not see the scooter. Making yourself conspicuous appears to be very effective in reducing the chance of this type of accident.

## Therefore:

- Wear a brightly colored jacket.
- Use extra caution when approaching and passing through intersections, since intersections are the most likely places for scooter accidents to occur.
- Ride where other motorists can see you. Avoid riding in another motorist's blind spot.

- Many accidents involve inexperienced operators. In fact, many operators who have been involved in accidents do not even have a current driver's license.
- Make sure that you are qualified and that you only lend your scooter to other qualified operators.
- Know your skills and limits. Staying within your limits may help you to avoid an accident.
- We recommend that you practice riding your scooter where there is no traffic until you have become thoroughly familiar with the scooter and all of its controls.
- Many accidents have been caused by error of the scooter operator. A typical error made by the operator is veering wide on a turn due to **EXCESSIVE SPEED** or undercornering (insufficient lean angle for the speed).
- Always obey the speed limit and never travel faster than warranted by road and traffic conditions.



- Always signal before turning or changing lanes. Make sure that other motorists can see you.
- The posture of the operator and passenger is important for proper control.
- The operator should keep both hands on the handlebar and both feet on the footboard during operation to maintain control of the scooter.
- The passenger should always hold onto the operator, the seat strap or grab bar, if equipped, with both hands and keep both feet on the passenger foot-rests.
- Never carry a passenger unless he or she can firmly place both feet on the passenger foot-rests.
- Never ride under the influence of alcohol or other drugs.
- This scooter is designed for on-road use only. It is not suitable for off-road use.

### Protective apparel

The majority of fatalities from scooter

accidents are the result of head injuries. The use of a safety helmet is the single most critical factor in the prevention or reduction of head injuries.

- Always wear an approved helmet.
- Wear a face shield or goggles. Wind in your unprotected eyes could contribute to an impairment of vision which could delay seeing a hazard.
- The use of a jacket, substantial shoes, trousers, gloves, etc., is effective in preventing or reducing abrasions or lacerations.
- Never wear loose-fitting clothes, otherwise they could catch on the control levers or wheels and cause injury or an accident.
- Never touch the engine or exhaust system during or after operation. They become very hot and can cause burns. Always wear protective clothing that covers your legs, ankles, and feet.
- Passengers should also observe the above precautions.

### Modifications

Modifications made to this scooter not approved by Yamaha, or the removal of

original equipment, may render the scooter unsafe for use and may cause severe personal injury. Modifications may also make your scooter illegal to use.

### Loading and accessories

Adding accessories or cargo to your scooter can adversely affect stability and handling if the weight distribution of the scooter is changed. To avoid the possibility of an accident, use extreme caution when adding cargo or accessories to your scooter. Use extra care when riding a scooter that has added cargo or accessories. Here are some general guidelines to follow if loading cargo or adding accessories to your scooter:

#### Loading

The total weight of the operator, passenger, accessories and cargo must not exceed the maximum load limit.

**Maximum load:**  
177 kg (390 lb)

# SAFETY INFORMATION

---

When loading within this weight limit, keep the following in mind:

- Cargo and accessory weight should be kept as low and close to the scooter as possible. Make sure to distribute the weight as evenly as possible on both sides of the scooter to minimize imbalance or instability.
- Shifting weights can create a sudden imbalance. Make sure that accessories and cargo are securely attached to the scooter before riding. Check accessory mounts and cargo restraints frequently.
- Never attach any large or heavy items to the handlebar, front fork, or front fender. Such items can create unstable handling or a slow steering response.

## Accessories

Genuine Yamaha accessories have been specifically designed for use on this scooter. Since Yamaha cannot test all other accessories that may be available, you must personally be responsible for the proper selection, installation and use of non-Yamaha accessories. Use

extreme caution when selecting and installing any accessories.

Keep the following guidelines in mind, as well as those provided under “Loading” when mounting accessories.

- Never install accessories or carry cargo that would impair the performance of your scooter. Carefully inspect the accessory before using it to make sure that it does not in any way reduce ground clearance or cornering clearance, limit suspension travel, steering travel or control operation, or obscure lights or reflectors.
- Accessories fitted to the handlebar or the front fork area can create instability due to improper weight distribution or aerodynamic changes. If accessories are added to the handlebar or front fork area, they must be as lightweight as possible and should be kept to a minimum.
- Bulky or large accessories may seriously affect the stability of the scooter due to aerodynamic effects. Wind may attempt to

lift the scooter, or the scooter may become unstable in cross winds. These accessories may also cause instability when passing or being passed by large vehicles.

- Certain accessories can displace the operator from his or her normal riding position. This improper position limits the freedom of movement of the operator and may limit control ability, therefore, such accessories are not recommended.
- Use caution when adding electrical accessories. If electrical accessories exceed the capacity of the scooter’s electrical system an electric failure could result, which could cause a dangerous loss of lights or engine power.

## **Gasoline and exhaust gas**

- **GASOLINE IS HIGHLY FLAMMABLE:**
  - Always turn the engine off when refueling.

- Take care not to spill any gasoline on the engine or exhaust system when refueling.
- Never refuel while smoking or in the vicinity of an open flame.
- Never start the engine or let it run for any length of time in a closed area. The exhaust fumes are poisonous and may cause loss of consciousness and death within a short time. Always operate your scooter in an area that has adequate ventilation.
- Always turn the engine off before leaving the scooter unattended and remove the key from the main switch. When parking the scooter, note the following:
  - The engine and exhaust system may be hot, therefore, park the scooter in a place where pedestrians or children are not likely to touch these hot areas.
  - Do not park the scooter on a slope or soft ground, otherwise it may fall over.
  - Do not park the scooter near a flammable source (e.g., a

kerosene heater, or near an open flame), otherwise it could catch fire.

- If you should swallow any gasoline, inhale a lot of gasoline vapor, or allow gasoline to get into your eyes, see your doctor immediately. If any gasoline spills on your skin or clothing, immediately wash the affected area with soap and water and change your clothes.

### **Further safe-riding points**

- Make sure to signal clearly when making turns.
- Braking can be extremely difficult on a wet road. Avoid hard braking, because the scooter could slide. Apply the brakes slowly when stopping on a wet surface.
- Slow down as you approach a corner or turn. Once you have completed a turn, accelerate slowly.
- Be careful when passing parked cars. A driver might not see you and open a door in your path.
- Railroad crossings, streetcar rails, iron plates on road construction sites, and manhole covers become extremely slippery when wet. Slow down and cross them with caution. Keep the scooter upright, otherwise it could slide out from under you.
- The brake lining could get wet when you wash the scooter. After washing the scooter, check the brakes before riding.
- Always wear a helmet, gloves, trousers (tapered around the cuff and ankle so they do not flap), and a

## SAFETY INFORMATION

---

bright colored jacket.

- Do not carry too much luggage on the scooter. An overloaded scooter is unstable.

1



# DESCRIPTION

EAU10410

## Left view

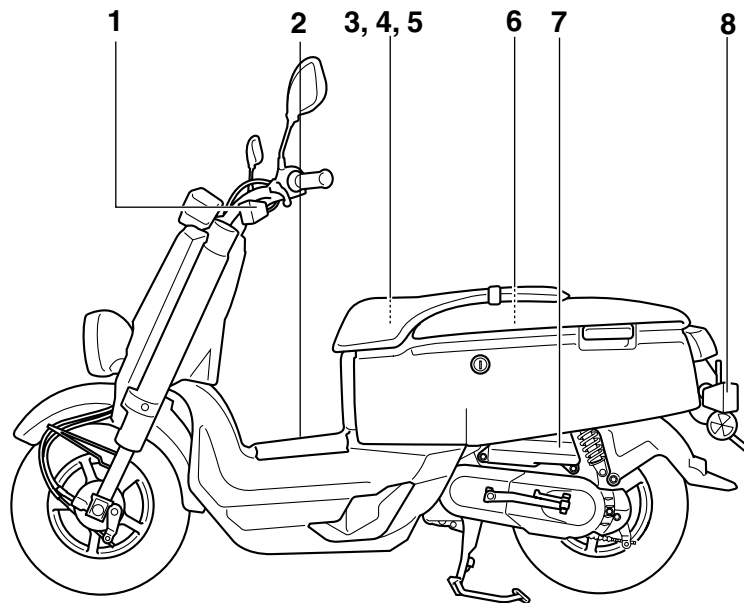

1. Front turn signal light (page 6-24)
2. Fuel tank cap (page 3-6)
3. Luggage hook (page 3-9)
4. Helmet holder (page 3-9)
5. Battery (page 6-20)
6. Storage compartment (page 3-10)
7. Air filter (page 6-12)
8. Rear turn signal light (page 6-24)

EAU10420

## Right view

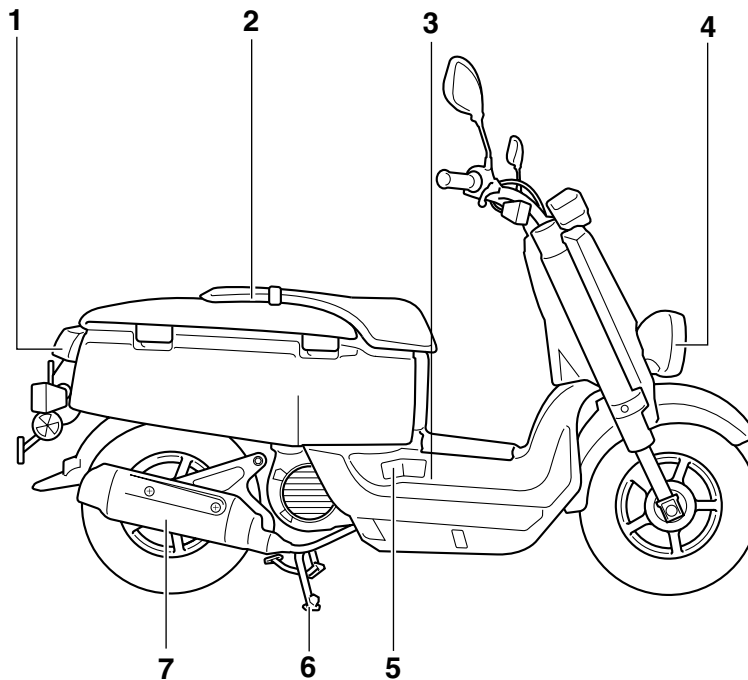

1. Tail/brake light (page 6-23)
2. Seat (page 3-9)
3. Coolant reservoir (page 6-10)
4. Headlight (page 6-22)
5. Spark plug (page 6-6)
6. Centerstand (page 6-18)
7. Muffler (page 3-8)

# DESCRIPTION

---

EAU10430

## Controls and instruments

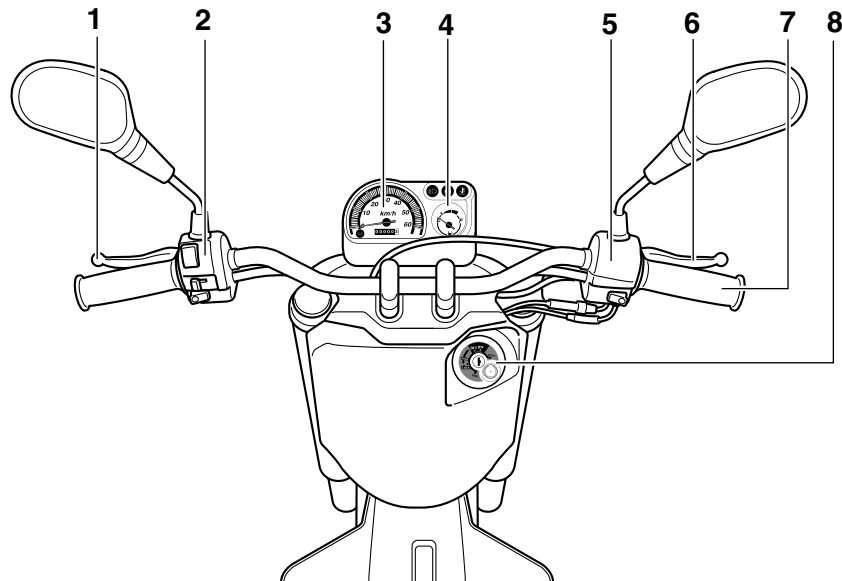

1. Rear brake lever (page 3-6)
2. Left handlebar switches (page 3-5)
3. Speedometer unit (page 3-4)
4. Fuel gauge (page 3-4)
5. Right handlebar switch (page 3-5)
6. Front brake lever (page 3-6)
7. Throttle grip (page 6-17)
8. Main switch/steering lock (page 3-1)



# INSTRUMENT AND CONTROL FUNCTIONS

## Main switch/steering lock

EAU10460

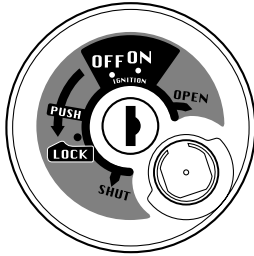

ZAJM00\*

The main switch/steering lock controls the ignition and lighting systems, and is used to lock the steering. The various positions are described below.

### (15P1/15P2)

EAUT2270

#### ON

All electrical circuits are supplied with power, and the meter lighting and tail-light come on, and the engine can be started. The key cannot be removed.

#### NOTE:

The headlight comes on automatically when the engine is started and stays on until the key is turned to "OFF".

### (15P3/15P4)

EAUT2060

#### ON

All electrical circuits are supplied with power, and the meter lighting, taillight, and license plate light come on, and the engine can be started. The key cannot be removed.

#### NOTE:

The headlight comes on automatically when the engine is started and stays on until the key is turned to "OFF", even if the engine stalls.

EAU10660

#### OFF

All electrical systems are off. The key can be removed.

## LOCK

EAU10680

The steering is locked, and all electrical systems are off. The key can be removed.

### To lock the steering

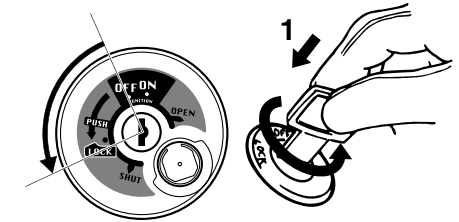

ZAJM00\*

#### 1. Push.

1. Turn the handlebars all the way to the left.
2. Push the key in from the "OFF" position, and then turn it to "LOCK" while still pushing it.
3. Remove the key.

# INSTRUMENT AND CONTROL FUNCTIONS

To unlock the steering

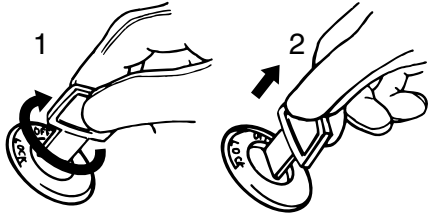

ZAJUM00\*\*

1. Turn.
2. Release.

Push the key in, and then turn it to “OFF” while still pushing it.

EWA10060

## **⚠ WARNING**

Never turn the key to “OFF” or “LOCK” while the vehicle is moving, otherwise the electrical systems will be switched off, which may result in loss of control or an accident. Make sure that the vehicle is stopped before turning the key to “OFF” or “LOCK”.

## Keyhole cover

EAUJ2120

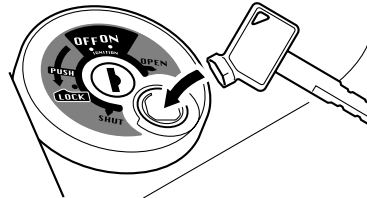

ZAJUM00\*\*

### To open the keyhole cover

Insert the key bow into the keyhole cover receptacle as shown, and then turn the key to “OPEN” to open the cover.

### To close the keyhole cover

Insert the key bow into the keyhole cover receptacle as shown, and then turn the key to “SHUT” to close the cover.

## Indicator and warning lights (15P1/15P2/15P4)

EAU11003

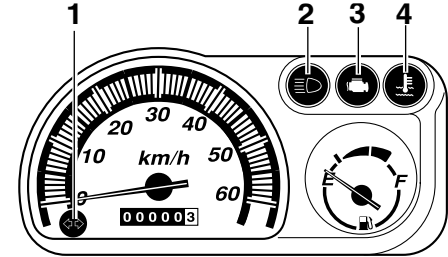

ZAJUM00\*\*

### (15P3)

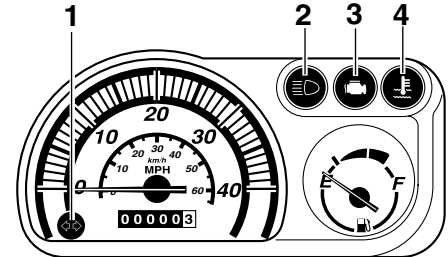

ZAJUM00\*\*

1. Turn signal indicator light "↔"
2. High beam indicator light "≡"
3. Engine trouble warning light "⚠"
4. Coolant temperature warning light "🔥"

# INSTRUMENT AND CONTROL FUNCTIONS

## Turn signal indicator light “”<sup>EAU11020</sup>

This indicator light flashes when the turn signal switch is pushed to the left or right.

## High beam indicator light “”<sup>EAU11080</sup>

This indicator light comes on when the high beam of the headlight is switched on.

## Coolant temperature warning light “”<sup>EAU11440</sup>

This warning light comes on when the engine overheats. When this occurs, stop the engine immediately and allow the engine to cool.

The electrical circuit of the warning light can be checked by turning the key to “ON”.

If the warning light does not come on for a few seconds, then go off, have a Yamaha dealer check the electrical circuit.

ECA10020

### **CAUTION:** \_\_\_\_\_

**Do not operate the engine if it is overheated.**

---

## Engine trouble warning light “”<sup>EAUT1930</sup>

This warning light flashes when an electrical circuit monitoring the engine is defective. When this occurs, have a Yamaha dealer check the self-diagnosis system.

The electrical circuit of the warning light can be checked by turning the key to “ON”. If the warning light does not come on for a few seconds, then go off, have a Yamaha dealer check the electrical circuit.

# INSTRUMENT AND CONTROL FUNCTIONS

## Speedometer unit (15P1/15P2/15P4)

EAUT2310

The speedometer unit is equipped with a speedometer and an odometer. The speedometer shows the riding speed. The odometer shows the total distance traveled.

### NOTE:

For the U.K.: The odometer units are displayed in miles.

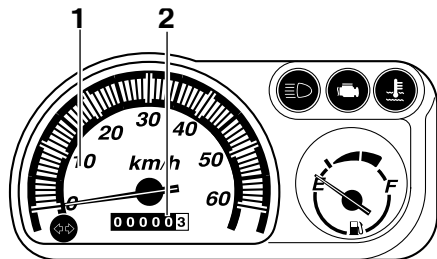

ZAJM00\*\*

(15P3)

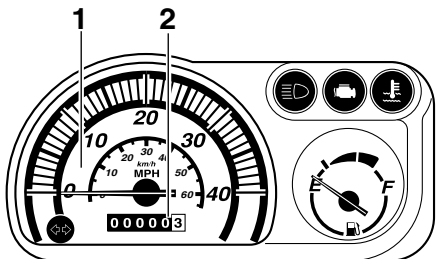

ZAJM00\*\*

1. Speedometer
2. Odometer

## Fuel gauge (15P1/15P2/15P4)

EAU12150

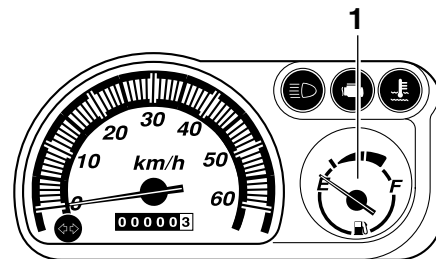

ZAJM00\*\*

(15P3)

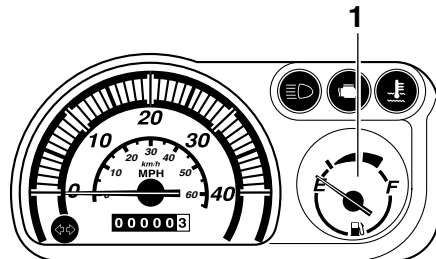

ZAJM00\*\*

1. Fuel gauge

# INSTRUMENT AND CONTROL FUNCTIONS

The fuel gauge indicates the amount of fuel in the fuel tank. The needle moves towards "E" (Empty) as the fuel level decreases. When the needle reaches the red line, refuel as soon as possible.

**NOTE:** \_\_\_\_\_  
Do not allow the fuel tank to empty itself completely.

## Handlebar switches

EAU12347

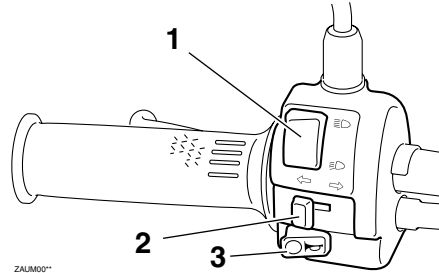

1. Dimmer switch "☰☑☰"
2. Turn signal switch "↔↔"
3. Horn switch "📣"

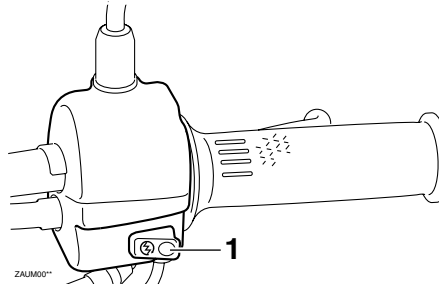

1. Start switch "⚡"

## Dimmer switch "☰☑☰"

EAU12400

Set this switch to "☰☑☰" for the high beam and to "☰☑" for the low beam.

## Turn signal switch "↔↔"

EAU12460

To signal a right-hand turn, push this switch to "↔↔". To signal a left-hand turn, push this switch to "↔↔". When released, the switch returns to the center position. To cancel the turn signal lights, push the switch in after it has returned to the center position.

3

## Horn switch "📣"

EAU12500

Press this switch to sound the horn.

## Start switch "⚡"

EAU11131

Push this switch while applying the front or rear brake to crank the engine with the starter.

ECA10050

## CAUTION: \_\_\_\_\_

See page 5-1 for starting instructions prior to starting the engine.

# INSTRUMENT AND CONTROL FUNCTIONS

## Front brake lever

EAU12900

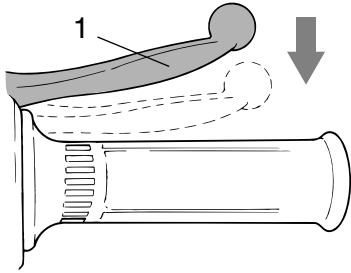

1. Front brake lever

The front brake lever is located on the right handlebar grip. To apply the front brake, pull this lever toward the handlebar grip.

## Rear brake lever

EAU12950

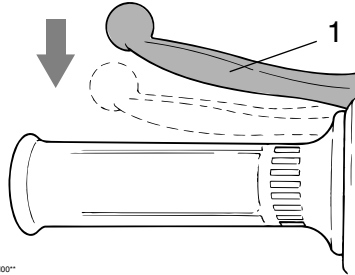

1. Rear brake lever

The rear brake lever is located on the left handlebar grip. To apply the rear brake, pull this lever toward the handlebar grip.

## Fuel tank cap

EAUT2280

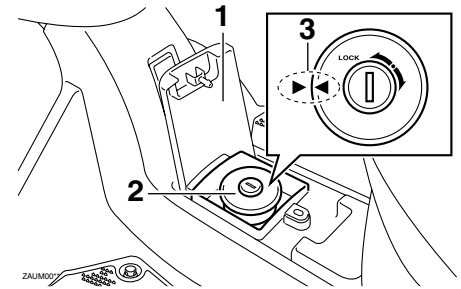

1. Fuel tank cap lid
2. Fuel tank cap
3. Match marks

### To remove the fuel tank cap

Open the lid, insert the key into the lock, and then turn it 1/4 turn clockwise. The lock will be released and the fuel tank cap can be removed.

### To install the fuel tank cap

1. Insert the fuel tank cap into the tank opening with the key inserted in the lock and the match marks aligned.
2. Turn the key counterclockwise to the original position, remove it, and then close the lid.

# INSTRUMENT AND CONTROL FUNCTIONS

## NOTE:

The fuel tank cap cannot be installed unless the key is in the lock. In addition, the key cannot be removed if the cap is not properly installed and locked.

EWA10130

## ⚠ WARNING

**Make sure that the fuel tank cap is properly installed before riding.**

## Fuel

EAU13211

ECA10070

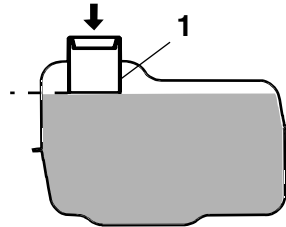

ZAJM00\*

1. Fuel tank filler tube

Make sure that there is sufficient fuel in the tank. Fill the fuel tank to the bottom of the filler tube as shown.

EWA10880

## ⚠ WARNING

- Do not overfill the fuel tank, otherwise it may overflow when the fuel warms up and expands.
- Avoid spilling fuel on the hot engine.

## CAUTION:

**Immediately wipe off spilled fuel with a clean, dry, soft cloth, since fuel may deteriorate painted surfaces or plastic parts.**

EAU33520

### Recommended fuel:

REGULAR UNLEADED GASOLINE ONLY

Fuel tank capacity:

4.5 L (1.19 US gal) (0.99 Imp.gal)

ECA11400

## CAUTION:

**Use only unleaded gasoline. The use of leaded gasoline will cause severe damage to internal engine parts, such as the valves and piston rings, as well as to the exhaust system.**

Your Yamaha engine has been designed to use regular unleaded gasoline with a research octane number of 91 or higher. If knocking (or pinging) occurs, use a gasoline of a different brand or premium unleaded fuel. Use of unleaded fuel will

# INSTRUMENT AND CONTROL FUNCTIONS

extend spark plug life and reduce maintenance costs.

3

## Catalytic converter

EAU13441

This vehicle is equipped with catalytic converters in the exhaust system.

EWA10860

### **⚠ WARNING**

The exhaust system is hot after operation. Make sure that the exhaust system has cooled down before doing any maintenance work.

ECA10700

### **CAUTION:**

The following precautions must be observed to prevent a fire hazard or other damages.

- Use only unleaded gasoline. The use of leaded gasoline will cause unreparable damage to the catalytic converter.
- Never park the vehicle near possible fire hazards such as grass or other materials that easily burn.
- Do not allow the engine to idle too long.

## Kickstarter

EAU13680

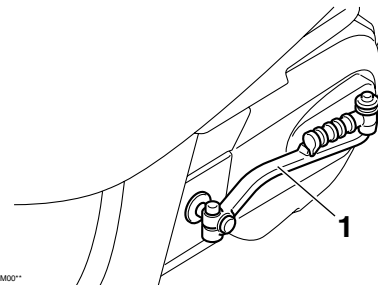

### 1. Kickstarter

To start the engine, fold out the kickstarter lever, move it down lightly with your foot until the gears engage, and then push it down smoothly but forcefully.



# INSTRUMENT AND CONTROL FUNCTIONS

## Seat

EAU13891

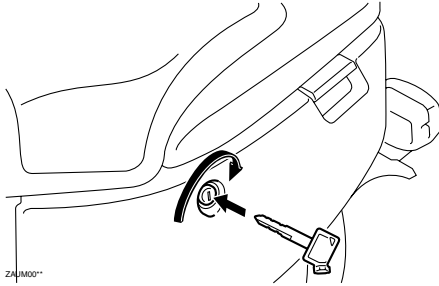

### To open the seat

1. Insert the key in the lock, and then turn it as shown.
2. Fold the seat up.

### To close the seat

1. Fold the seat down, and then push it down to lock it in place.
2. Remove the key.

**NOTE:** \_\_\_\_\_  
Make sure that the seat is properly secured before riding.  
\_\_\_\_\_

## Luggage hook

EAUT2050

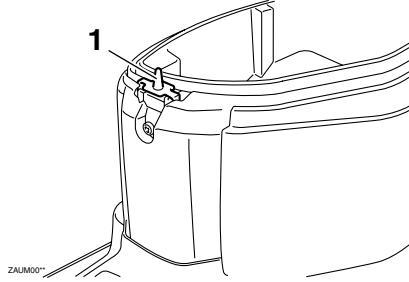

1. Luggage hook

The luggage hook is located under the seat. (see page 3-9)

EAWAT1030

### **⚠ WARNING**

- Do not exceed the load limit of 1.0 kg (2.2 lb) for the luggage hook.
- Do not exceed the maximum load of 177 kg (390 lb) for the vehicle.

## Helmet holder

EAUT2040

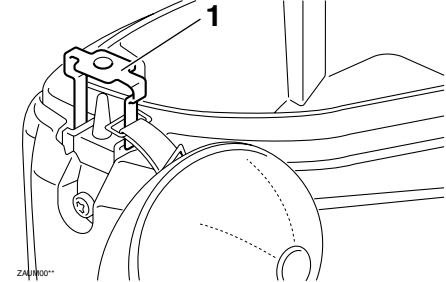

1. Helmet holder

The helmet holder is located under the seat.

### To secure a helmet to the helmet holder

1. Open the seat. (See page 3-9.)
2. Pull the helmet holder up.
3. Attach the helmet to the helmet holder and then push the helmet holder down.
4. Securely close the seat.

# INSTRUMENT AND CONTROL FUNCTIONS

EWA10160

## **⚠ WARNING**

Never ride with a helmet attached to the helmet holder, since the helmet may hit objects, causing loss of control and possibly an accident.

### To release the helmet from the helmet holder

1. Open the seat, pull the helmet holder up and remove the helmet from the helmet holder, and then push the helmet holder down.
2. Securely close the seat.

## Storage compartment

EAU14451

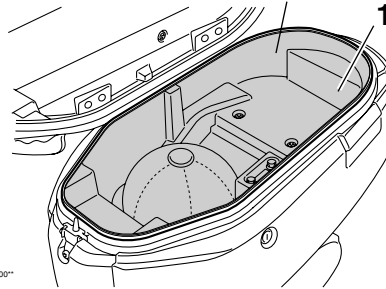

1. Storage compartment

The storage compartment is located under the seat. (See page 3-9.)

EWA10961

## **⚠ WARNING**

- Do not exceed the load limit of 5 kg (11 lb) for the storage compartment.
- Do not exceed the maximum load of 177 kg (390 lb) for the vehicle.

When storing the owner's manual or other documents in the storage com-

partment, be sure to wrap them in a plastic bag so that they will not get wet. When washing the vehicle, be careful not to let any water enter the storage compartment.

# PRE-OPERATION CHECKS

---

---

EAU15593

The condition of a vehicle is the owner's responsibility. Vital components can start to deteriorate quickly and unexpectedly, even if the vehicle remains unused (for example, as a result of exposure to the elements). Any damage, fluid leakage or loss of tire air pressure could have serious consequences. Therefore, it is very important, in addition to a thorough visual inspection, to check the following points before each ride.

**NOTE:**

Pre-operation checks should be made each time the vehicle is used. Such an inspection can be accomplished in a very short time; and the added safety it assures is more than worth the time involved.

---

EWA11150

**⚠ WARNING**

If any item in the Pre-operation check list is not working properly, have it inspected and repaired before operating the vehicle.

---

# PRE-OPERATION CHECKS

EAU15605

## Pre-operation check list

ITEM	CHECKS	PAGE
<b>Fuel</b>	<ul style="list-style-type: none"><li>• Check fuel level in fuel tank.</li><li>• Refuel if necessary.</li><li>• Check fuel line for leakage.</li></ul>	3-7
<b>Engine oil</b>	<ul style="list-style-type: none"><li>• Check oil level in engine.</li><li>• If necessary, add recommended oil to specified level.</li><li>• Check vehicle for oil leakage.</li></ul>	6-7
<b>Final transmission oil</b>	<ul style="list-style-type: none"><li>• Check vehicle for oil leakage.</li></ul>	6-9
<b>Coolant</b>	<ul style="list-style-type: none"><li>• Check coolant level in reservoir</li><li>• If necessary, add recommended coolant to specified level.</li><li>• Check cooling system for leakage.</li></ul>	6-10
<b>Front brake</b>	<ul style="list-style-type: none"><li>• Check operation.</li><li>• Lubricate cable if necessary.</li><li>• Check lever free play.</li><li>• Adjust if necessary.</li></ul>	6-15,6-16
<b>Rear brake</b>	<ul style="list-style-type: none"><li>• Check operation.</li><li>• Lubricate cable if necessary.</li><li>• Check lever free play.</li><li>• Adjust if necessary.</li></ul>	6-16~6-17
<b>Throttle grip</b>	<ul style="list-style-type: none"><li>• Make sure that operation is smooth.</li><li>• Check cable free play.</li><li>• If necessary, have Yamaha dealer adjust cable free play and lubricate cable and grip housing.</li></ul>	6-17
<b>Wheels and tires</b>	<ul style="list-style-type: none"><li>• Check for damage.</li><li>• Check tire condition and tread depth.</li><li>• Check air pressure.</li><li>• Correct if necessary.</li></ul>	6-13~6-15
<b>Brake levers</b>	<ul style="list-style-type: none"><li>• Make sure that operation is smooth.</li><li>• Lubricate lever pivoting points if necessary.</li></ul>	6-17

4

# PRE-OPERATION CHECKS

ITEM	CHECKS	PAGE
<b>Centerstand</b>	<ul style="list-style-type: none"><li>• Make sure that operation is smooth.</li><li>• Lubricate pivots if necessary.</li></ul>	6-18
<b>Chassis fasteners</b>	<ul style="list-style-type: none"><li>• Make sure that all nuts, bolts and screws are properly tightened.</li><li>• Tighten if necessary.</li></ul>	-
<b>Instruments, lights, signals and switches</b>	<ul style="list-style-type: none"><li>• Check operation.</li><li>• Correct if necessary.</li></ul>	3-2,3-5

# OPERATION AND IMPORTANT RIDING POINTS

---

EAU15980  
EWA10870

## **⚠ WARNING**

- Become thoroughly familiar with all operating controls and their functions before riding. Consult a Yamaha dealer regarding any control or function that you do not thoroughly understand.
  - Never start the engine or operate it in a closed area for any length of time. Exhaust fumes are poisonous, and inhaling them can cause loss of consciousness and death within a short time. Always make sure that there is adequate ventilation.
  - For safety, always start the engine with the centerstand down.
- 

## Starting the engine

EAUT2250

ECA10250

### **CAUTION:**

See page 5-3 for engine break-in instructions prior to operating the vehicle for the first time.

---

1. Turn the key to “ON”.

ECAT1070

### **CAUTION:**

The engine trouble warning light and coolant temperature warning light should come on for a few seconds, then go off. If these warning lights do not go off, have a Yamaha dealer check their electrical circuits.

---

2. Close the throttle completely.
3. Start the engine by pushing the start switch while applying the front or rear brake.

### **NOTE:**

If the engine does not start, release the start switch, wait a few seconds, and then try again. Each starting attempt should be as short as possible to pre-

serve the battery. Do not crank the engine more than 5 seconds on any one attempt. If the engine does not start with the starter motor, try using the kickstarter.

---

ECA11040

### **CAUTION:**

For maximum engine life, never accelerate hard when the engine is cold!

---

# OPERATION AND IMPORTANT RIDING POINTS

## Starting off

EAU16760

### NOTE:

Before starting off, allow the engine to warm up.

1. While pulling the rear brake lever with your left hand and holding the grab bar with your right hand, push the scooter off the centerstand.
2. Sit astride the seat, and then adjust the rear view mirrors.
3. Switch the turn signal on.
4. Check for oncoming traffic, and then slowly turn the throttle grip (on the right) in order to take off.
5. Switch the turn signal off.

## Acceleration and deceleration

EAU16780

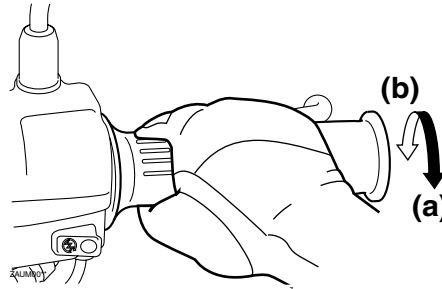

The speed can be adjusted by opening and closing the throttle. To increase the speed, turn the throttle grip in direction (a). To reduce the speed, turn the throttle grip in direction (b).

## Braking

1. Close the throttle completely.
2. Apply both front and rear brakes simultaneously while gradually increasing the pressure.

EAU16792

### **WARNING**

- Avoid braking hard or suddenly (especially when leaning over to one side), otherwise the scooter may skid or overturn.
- Railroad crossings, streetcar rails, iron plates on road construction sites, and manhole covers become extremely slippery when wet. Therefore, slow down when approaching such areas and cross them with caution.
- Keep in mind that braking on a wet road is much more difficult.
- Ride slowly down a hill, as braking downhill can be very difficult.

EWA10300

# OPERATION AND IMPORTANT RIDING POINTS

---

5

## Engine break-in

EAU16830

There is never a more important period in the life of your engine than the period between 0 and 1000 km (600 mi). For this reason, you should read the following material carefully.

Since the engine is brand new, do not put an excessive load on it for the first 1000 km (600 mi). The various parts in the engine wear and polish themselves to the correct operating clearances. During this period, prolonged full-throttle operation or any condition that might result in engine overheating must be avoided.

## 0 ~ 150 km (0 ~ 90 mi)

EAU16950

Avoid prolonged operation above 1/3 throttle.

After every hour of operation, stop the engine, and then let it cool for five to ten minutes.

Vary the engine speed from time to time. Do not operate the engine at one set throttle position.

## 150 ~ 500 km (90 ~ 300 mi)

Avoid prolonged operation above 1/2 throttle.

Rev the engine freely through the gears, but do not use full throttle at any time.

## 500 ~ 1000 km (300 ~ 600 mi)

Avoid prolonged operation above 3/4 throttle.

ECA10350

### CAUTION:

**After 1000 km (600 mi) of operation, the engine oil must be changed and the oil strainer cleaned.**

## 1000 km (600 mi) and beyond

Avoid prolonged full-throttle operation. Vary the speed occasionally.

ECA10270

### CAUTION:

**If any engine trouble should occur during the engine break-in period, immediately have a Yamaha dealer check the vehicle.**

EAU17212

## Parking

When parking, stop the engine, and then remove the key from the main switch.

EWA10310

### ⚠ WARNING

- **Since the engine and exhaust system can become very hot, park in a place where pedestrians or children are not likely to touch them.**
- **Do not park on a slope or on soft ground, otherwise the vehicle may overturn.**

ECA10380

### CAUTION:

**Never park in an area where there are fire hazards such as grass or other flammable materials.**



# PERIODIC MAINTENANCE AND MINOR REPAIR

---

EAU17280

Safety is an obligation of the owner. Periodic inspection, adjustment and lubrication will keep your vehicle in the safest and most efficient condition possible. The most important points of inspection, adjustment, and lubrication are explained on the following pages.

The intervals given in the periodic maintenance and lubrication chart should be simply considered as a general guide under normal riding conditions. However, DEPENDING ON THE WEATHER, TERRAIN, GEOGRAPHICAL LOCATION, AND INDIVIDUAL USE, THE MAINTENANCE INTERVALS MAY NEED TO BE SHORTENED.

EWA10320

## **⚠ WARNING**

**If you are not familiar with maintenance work, have a Yamaha dealer do it for you.**

---

EWA10330

## **⚠ WARNING**

**This scooter is designed for use on paved roads only. If this scooter is operated in abnormally dusty, muddy**

**or wet conditions, the air filter element should be cleaned or replaced more frequently, otherwise rapid engine wear may result. Consult a Yamaha dealer for proper maintenance intervals.**

---

# PERIODIC MAINTENANCE AND MINOR REPAIR

EAU17715

## Periodic maintenance and lubrication chart

### NOTE:

- The annual checks must be performed every year, except if a kilometer-based maintenance, or for the UK, a mileage-based maintenance, is performed instead.
- From 30000 km (17500 mi), repeat the maintenance intervals starting from 6000 km (3500 mi).  
Items marked with an asterisk should be performed by a Yamaha dealer as they require special tools, data and technical skills.

NO.	ITEM	CHECK OR MAINTENANCE JOB	ODOMETER READING					ANNUAL CHECK
			1000 km (600 mi)	6000 km (3500 mi)	12000 km (7000 mi)	18000 km (10500 mi)	24000 km (14000 mi)	
1	* Fuel line	• Check fuel hoses and vacuum hose for cracks or damage.		√	√	√	√	√
2	Spark plug	• Check condition. • Clean and regap.		√		√		
		• Replace.			√		√	
3	* Valves	• Check and adjust valve clearance when engine is cold.		√	√	√	√	
4	* Air filter element	• Replace.		√	√	√	√	√
5	* Front brake	• Check operation and adjust brake lever free play.	√	√	√	√	√	√
		• Replace brake shoes.	Whenever worn to the limit					
6	* Rear brake	• Check operation and adjust brake lever free play.	√	√	√	√	√	√
		• Replace brake shoes.	Whenever worn to the limit					
7	* Wheels	• Check runout and for damage.		√	√	√	√	
8	* Tires	• Check tread depth and for damage. • Replace if necessary. • Check air pressure. • Correct if necessary.		√	√	√	√	√
9	* Wheel bearings	• Check bearing for looseness or damage.		√	√	√	√	

# PERIODIC MAINTENANCE AND MINOR REPAIR

NO.	ITEM	CHECK OR MAINTENANCE JOB	ODOMETER READING					ANNUAL CHECK
			1000 km (600 mi)	6000 km (3500 mi)	12000 km (7000 mi)	18000 km (10500 mi)	24000 km (14000 mi)	
10	* Steering bearings	<ul style="list-style-type: none"> <li>• Check bearing assemblies for looseness.</li> <li>• Moderately repack with lithium-soap-based grease every 12000 km (7000 mi) or 24 months.</li> </ul>	√	√	Repack.	√	Repack.	√
11	* Chassis fasteners	<ul style="list-style-type: none"> <li>• Make sure that all nuts, bolts and screws are properly tightened.</li> </ul>		√	√	√	√	√
12	Front brake lever pivot shaft	<ul style="list-style-type: none"> <li>• Lubricate with lithium-soap-based grease.</li> </ul>		√	√	√	√	√
13	Rear brake lever pivot shaft	<ul style="list-style-type: none"> <li>• Lubricate with lithium-soap-based grease.</li> </ul>		√	√	√	√	√
14	Centerstand	<ul style="list-style-type: none"> <li>• Check operation.</li> <li>• Lubricate.</li> </ul>		√	√	√	√	√
15	* Front fork	<ul style="list-style-type: none"> <li>• Check operation and for oil leakage.</li> </ul>		√	√	√	√	
16	* Shock absorber assembly	<ul style="list-style-type: none"> <li>• Check operation and shock absorber for oil leakage.</li> </ul>		√	√	√	√	
17	* Fuel injection	<ul style="list-style-type: none"> <li>• Check engine idle speed.</li> </ul>	√	√	√	√	√	√
18	Engine oil	<ul style="list-style-type: none"> <li>• Change. (See page 6-7.)</li> <li>• Check oil level and vehicle for oil leakage.</li> </ul>	√	Every 3000 km (1750 mi)				
19	* Engine oil strainer	<ul style="list-style-type: none"> <li>• Clean.</li> </ul>	√	Every 6000 km (3500 mi)				
20	* Cooling system	<ul style="list-style-type: none"> <li>• Check coolant level and vehicle for coolant leakage.</li> <li>• Change.</li> </ul>		√	√	√	√	√
21	Final transmission oil	<ul style="list-style-type: none"> <li>• Check vehicle for oil leakage.</li> <li>• Change.</li> </ul>	√	√	√	√	√	
22	* V-belt	<ul style="list-style-type: none"> <li>• Replace.</li> </ul>	Every 10000 km (6000 mi)					
23	* Front and rear brake switches	<ul style="list-style-type: none"> <li>• Check operation.</li> </ul>	√	√	√	√	√	√
24	Moving parts and cables	<ul style="list-style-type: none"> <li>• Lubricate.</li> </ul>		√	√	√	√	√

# PERIODIC MAINTENANCE AND MINOR REPAIR

NO.	ITEM	CHECK OR MAINTENANCE JOB	ODOMETER READING					ANNUAL CHECK
			1000 km (600 mi)	6000 km (3500 mi)	12000 km (7000 mi)	18000 km (10500 mi)	24000 km (14000 mi)	
25	* Throttle grip housing and cable	<ul style="list-style-type: none"> <li>• Check operation and free play.</li> <li>• Adjust the throttle cable free play if necessary.</li> <li>• Lubricate the throttle grip housing and cable.</li> </ul>		√	√	√	√	√
26	* Air induction system	<ul style="list-style-type: none"> <li>• Check the air cut-off valve, reed valve, and hose for damage.</li> <li>• Replace the entire air induction system if necessary.</li> </ul>		√	√	√	√	√
27	* Lights, signals and switches	<ul style="list-style-type: none"> <li>• Check operation.</li> <li>• Adjust headlight beam.</li> </ul>	√	√	√	√	√	√

# PERIODIC MAINTENANCE AND MINOR REPAIR

EAU18771

## Removing and installing panels

The panels shown need to be removed to perform some of the maintenance jobs described in this chapter. Refer to this section each time a panel needs to be removed and installed.

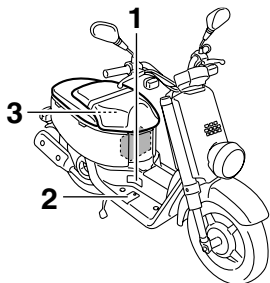

ZALIM00\*\*

1. Panel A
2. Panel B
3. Panel C

EAUT2100

### Panel A

To remove the panel

Slide the panel backward, and then pull it out as shown.

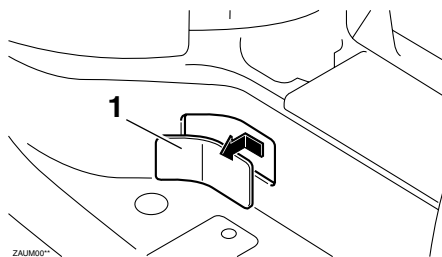

1. Panel A

To install the panel

Place and slide the panel into the original position.

### Panel B

To remove the panel

Remove the screw, and then take the panel off.

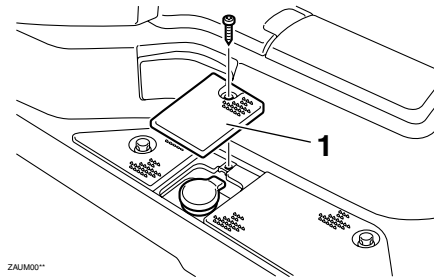

ZALIM00\*\*

1. Panel B

To install the panel

Place the panel in the original position, and then install the screw.

# PERIODIC MAINTENANCE AND MINOR REPAIR

## Panel C

To remove the panel

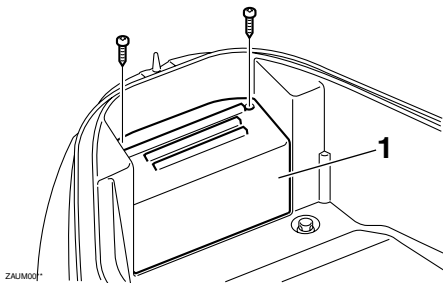

1. Panel C

1. Open the seat. (See page 3-9.)
2. Remove the screws, and then take the panel off.

To install the panel

Place the panel in the original position, and then install the screws.

EAUT2070

## Checking the spark plug

The spark plug is an important engine component, which is easy to check. Since heat and deposits will cause any spark plug to slowly erode, the spark plug should be removed and checked in accordance with the periodic maintenance and lubrication chart. In addition, the condition of the spark plug can reveal the condition of the engine.

## To remove the spark plug

1. Remove panel A. (See page 6-5.)
2. Remove the spark plug cap.

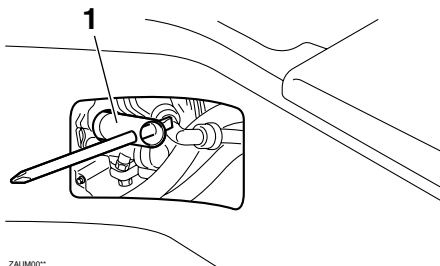

1. Spark plug wrench

3. Remove the spark plug as shown, with a spark plug wrench available at a Yamaha dealer.

## To check the spark plug

1. Check that the porcelain insulator around the center electrode of the spark plug is a medium-to-light tan (the ideal color when the vehicle is ridden normally).

## NOTE:

If the spark plug shows a distinctly different color, the engine could be operating improperly. Do not attempt to diagnose such problems yourself. Instead, have a Yamaha dealer check the vehicle.

2. Check the spark plug for electrode erosion and excessive carbon or other deposits, and replace it if necessary.

**Specified spark plug:**  
CR7E (NGK)

# PERIODIC MAINTENANCE AND MINOR REPAIR

EAUT1460

## To install the spark plug

1. Measure the spark plug gap with a wire thickness gauge and, if necessary, adjust the gap to specification.

### Spark plug gap:

0.7 ~ 0.8 mm (0.028 ~ 0.031 in)

2. Clean the surface of the spark plug gasket and its mating surface, and then wipe off any grime from the spark plug threads.
3. Install the spark plug with the spark plug wrench, and then tighten it to the specified torque.

### Tightening torque:

Spark plug:

13 Nm (1.3 m • kgf, 9.4ft • lbf)

## NOTE: \_\_\_\_\_

If a torque wrench is not available when installing a spark plug, a good estimate of the correct torque is 1/4~1/2 turn past finger tight. However, the spark plug should be tightened to the specified torque as soon as possible.

4. Install the spark plug cap.
5. Install the panel.

## Engine oil and oil strainer

The engine oil level should be checked before each ride. In addition, the oil must be changed and the oil strainer cleaned at the intervals specified in the periodic maintenance and lubrication chart.

## To check the engine oil level

1. Place the vehicle on the centerstand.

**NOTE:** \_\_\_\_\_  
Make sure that the vehicle is positioned straight up when checking the oil level. A slight tilt to the side can result in a false reading.

2. Start the engine, warm it up for several minutes, and then turn it off.

# PERIODIC MAINTENANCE AND MINOR REPAIR

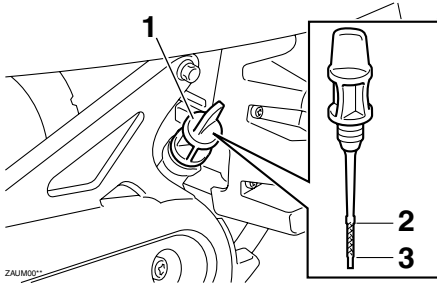

1. Engine oil filler cap
2. Maximum level mark
3. Minimum level mark

3. Wait a few minutes until the oil settles, remove the oil filler cap, wipe the dipstick clean, insert it back into the oil filler hole (without screwing it in), and then remove it again to check the oil level.

## NOTE:

The engine oil should be between the minimum and maximum level marks.

4. If the engine oil is below the minimum level mark, add sufficient oil of the recommended type to raise it to the correct level.

5. Insert the dipstick into the oil filler hole, and then tighten the oil filler cap.

## To change the engine oil and clean the oil strainer

1. Start the engine, warm it up for several minutes, and then turn it off.
2. Place an oil pan under the engine to collect the used oil.
3. Remove the engine oil filler cap and the engine oil drain bolts A and B to drain the oil from the crankcase.

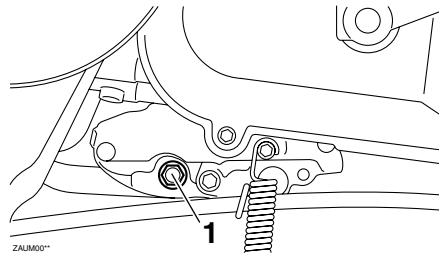

1. Engine oil drain bolt A

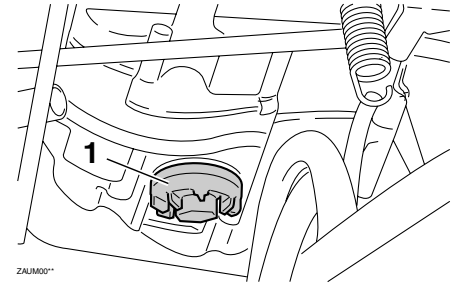

1. Engine oil drain bolt B

ECAT1020

## CAUTION:

**When removing the engine oil drain bolt B, the O-ring, compression spring, and oil strainer will fall out. Take care not to lose these parts.**

4. Clean the oil strainer with solvent, and then check it for damage and replace it if necessary.
5. Check the O-ring for damage and replace it if necessary.
6. Install the oil strainer, compression spring, O-ring and engine oil drain bolt B.



# PERIODIC MAINTENANCE AND MINOR REPAIR

EAUT1560

**NOTE:** \_\_\_\_\_  
Make sure that the O-ring is properly seated.

7. Install engine oil drain bolt A, and then tighten both drain bolts to their specified torques.

## Tightening torque:

Engine oil drain bolt A:

23 Nm (2.3 m • kgf, 16.6 ft • lbf)

Engine oil drain bolt B:

32 Nm (3.2 m • kgf, 23.1 ft • lbf)

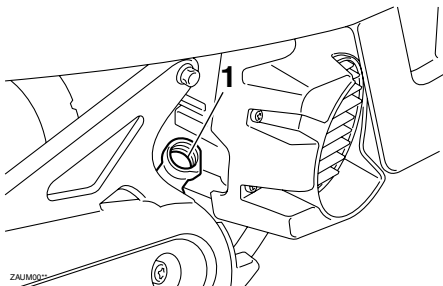

1. Oil filler hole

8. Add the specified amount of the recommended engine oil, and then install and tighten the oil filler cap.

## Recommended engine oil:

See page 8-1.

Oil change quantity:

0.78 L (0.82 US qt) (0.69 Imp.qt)

ECA11670

## CAUTION:

- Do not use oils with a diesel specification of “CD” or oils of a higher quality than specified. In addition, do not use oils labeled “ENERGY CONSERVING II” or higher.
- Be sure no foreign material enters the crankcase.

9. Start the engine, and then let it idle for several minutes while checking it for oil leakage. If oil is leaking, immediately turn the engine off and check for the cause.
10. Turn the engine off, and then check the oil level and correct it if necessary.

## Final transmission oil

The final transmission case must be checked for oil leakage before each ride. If any leakage is found, have a Yamaha dealer check and repair the scooter. In addition, the final transmission oil must be changed as follows at the intervals specified in the periodic maintenance and lubrication chart.

1. Start the engine, warm it up by riding the scooter for several minutes, and then stop the engine.
2. Place the scooter on the centerstand.
3. Place an oil pan under the final transmission case to collect the used oil.

# PERIODIC MAINTENANCE AND MINOR REPAIR

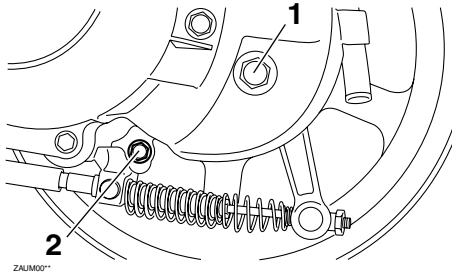

1. Final transmission oil filler bolt
2. Final transmission oil drain bolt

4. Remove the oil filler bolt and drain bolt to drain the oil from the final transmission case.
5. Install the final transmission oil drain bolt, and then tighten it to the specified torque.

## Tightening torque:

Final transmission oil drain bolt:  
13 Nm (1.3 m • kgf, 9.4 ft • lbf)

6. Add the specified amount of the recommended final transmission oil, and then install the oil filler bolt and tighten it to the specified torque.

## Tightening torque:

Final transmission oil filler bolt:  
23 Nm (2.3 m • kgf, 16.6 ft • lbf)

## Recommended final transmission oil:

See page 8-1.

## Oil quantity:

0.10 L (0.11 US qt) (0.09 Imp.qt)

EWA11310

## **⚠ WARNING**

- **Make sure that no foreign material enters the final transmission case.**
- **Make sure that no oil gets on the tire or wheel.**

7. Check the final transmission case for oil leakage. If oil is leaking, check for the cause.

EAU20070

## Coolant

The coolant level should be checked before each ride. In addition, the coolant must be changed at the intervals specified in the periodic maintenance and lubrication chart.

EAU1522

## To check the coolant level

The coolant level should be checked as follows before each ride. In addition, the coolant must be changed at the intervals specified in the periodic maintenance and lubrication chart.

1. Place the vehicle on the centerstand.

## NOTE:

- The coolant level must be checked on a cold engine since the level varies with engine temperature.
- Make sure that the vehicle is positioned straight up when checking the coolant level. A slight tilt to the side can result in a false reading.

2. Check the coolant level in the coolant reservoir.

# PERIODIC MAINTENANCE AND MINOR REPAIR

**NOTE:** \_\_\_\_\_  
The coolant should be between the minimum and maximum level marks.

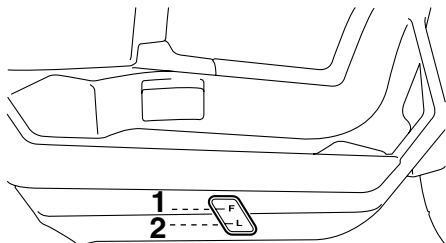

ZAJM00\*

1. Maximum level mark
2. Minimum level mark

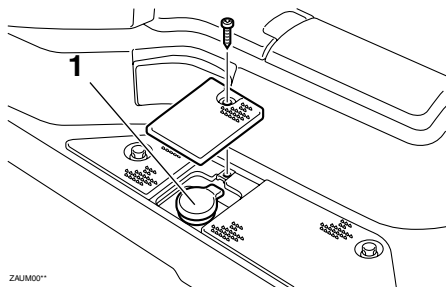

ZAJM00\*

1. Coolant reservoir cap

3. If the coolant is at or below the minimum level mark, remove panel B and the reservoir cap. (See page 6-5.)
4. Add coolant or distilled water to raise the coolant to the maximum level mark, and install the coolant reservoir cap and the panel.

**Coolant reservoir capacity:**  
0.26 L (0.27 US qt) (0.23 Imp.qt)

ECA10471

## **CAUTION:** \_\_\_\_\_

- If coolant is not available, use distilled water or soft tap water instead. Do not use hard water or salt water since it is harmful to the engine.
- If water has been used instead of coolant, replace it with coolant as soon as possible, otherwise the cooling system will not be protected against frost and corrosion.
- If water has been added to the coolant, have a Yamaha dealer check the antifreeze content of the coolant as soon as possible,

otherwise the effectiveness of the coolant will be reduced.

EWA10380

## **WARNING** \_\_\_\_\_

**Never attempt to remove the radiator cap when the engine is hot.**

**NOTE:** \_\_\_\_\_  
If the engine overheats, see page 6-26 for further instructions.

# PERIODIC MAINTENANCE AND MINOR REPAIR

---

EAUT1990

## Replacing the air filter element

The air filter element must be replaced and the check hoses must be cleaned at the intervals specified in the periodic maintenance and lubrication chart. Have a Yamaha dealer replace the air filter element.

EAU21382

## Checking the throttle cable free play

The throttle cable free play should measure 1.5 ~ 3.5 mm (0.06 ~ 0.14 in) at the throttle grip. Periodically check the throttle cable free play and, if necessary, have a Yamaha dealer adjust it.

EAU21401

## Valve clearance

The valve clearance changes with use, resulting in improper air-fuel mixture and/or engine noise. To prevent this from occurring, the valve clearance must be adjusted by a Yamaha dealer at the intervals specified in the periodic maintenance and lubrication chart.

# PERIODIC MAINTENANCE AND MINOR REPAIR

## Tires

EAUT2140

To maximize the performance, durability, and safe operation of your vehicle, note the following points regarding the specified tires.

### Tire air pressure

The tire air pressure should be checked and, if necessary, adjusted before each ride.

EWA10500

#### **⚠ WARNING**

- The tire air pressure must be checked and adjusted on cold tires (i.e., when the temperature of the tires equals the ambient temperature).
- The tire air pressure must be adjusted in accordance with the riding speed and with the total weight of rider, passenger, cargo, and accessories approved for this model.

#### Tire air pressure (measured on cold tires):

Up to 90 kg (198 lb):

Front:

175 kPa (25 psi) (1.75 kgf/cm<sup>2</sup>)

Rear:

175 kPa (25 psi) (1.75 kgf/cm<sup>2</sup>)

90 kg (198 lb) to maximum load:

Front:

175 kPa (25 psi) (1.75 kgf/cm<sup>2</sup>)

Rear:

175 kPa (25 psi) (1.75 kgf/cm<sup>2</sup>)

Maximum load\*:

177 kg (390 lb)

\* Total weight of rider, passenger, cargo and accessories

EWA11200

#### **⚠ WARNING**

Because loading has an enormous impact on the handling, braking, performance and safety characteristics of your vehicle, you should keep the following precautions in mind.

- **NEVER OVERLOAD THE VEHICLE!** Operation of an overloaded motorcycle may result in tire damage, loss of control, or severe injury. Make sure that the total weight of rider, passenger,

and accessories does not exceed the specified maximum load for the vehicle.

- Do not carry along loosely packed items, which can shift during a ride. Securely pack the heaviest items close to the center of the vehicle and distribute the weight evenly on both sides.
- Adjust the tire air pressure with regard to the load. Check the tire condition and air pressure before each ride.

# PERIODIC MAINTENANCE AND MINOR REPAIR

## Tire inspection

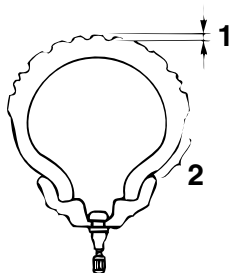

ZALUM00\*\*

1. Tire tread depth
2. Tire sidewall

The tires must be checked before each ride. If the center tread depth reaches the specified limit, if the tire has a nail or glass fragments in it, or if the sidewall is cracked, have a Yamaha dealer replace the tire immediately.

**Minimum tire tread depth (front and rear):**  
0.8 mm (0.03 in)

**NOTE:** \_\_\_\_\_  
The tire tread depth limits may differ from country to country. Always comply with the local regulations.  
\_\_\_\_\_

## Tire information

This model is equipped with tubeless tires.

### Front tire:

Size:  
120/90-10 57J  
Manufacturer/model:  
CHENG SHIN/C-6022

### Rear tire:

Size:  
120/90-10 57J  
Manufacturer/model:  
CHENG SHIN/C-6022

EWA10470

## **⚠ WARNING** \_\_\_\_\_

- **Have a Yamaha dealer replace excessively worn tires. Besides being illegal, operating the vehicle with excessively worn tires decreases riding stability and can lead to loss of control.**
- **The replacement of all wheel and**

**brake related parts, including the tires, should be left to a Yamaha dealer, who has the necessary professional knowledge and experience.**

# PERIODIC MAINTENANCE AND MINOR REPAIR

## Cast wheels

To maximize the performance, durability, and safe operation of your motorcycle, note the following points regarding the specified wheels.

- The wheel rims should be checked for cracks, bends or warpage before each ride. If any damage is found, have a Yamaha dealer replace the wheel. Do not attempt even the smallest repair to the wheel. A deformed or cracked wheel must be replaced.
- The wheel should be balanced whenever either the tire or wheel has been changed or replaced. An unbalanced wheel can result in poor performance, adverse handling characteristics, and a shortened tire life.
- Ride at moderate speeds after changing a tire since the tire surface must first be “broken in” for it to develop its optimal characteristics.

EAU21960

## Adjusting the brake lever free play

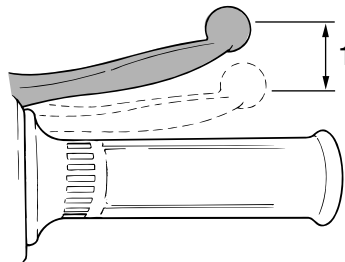

ZAJM00\*\*

### 1. Front brake lever free play

The brake lever free play should measure 10 ~ 20 mm (0.4 ~ 0.8 in) as shown. Periodically check the brake lever free play and, if necessary, adjust it as follows.

To increase the brake lever free play, turn the adjusting nut at the brake shoe plate in direction (a). To decrease the brake lever free play, turn the adjusting nut in direction (b).

EAU22130

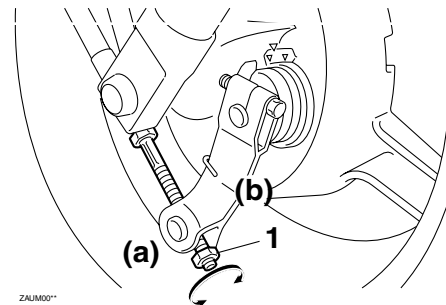

ZAJM00\*\*

### 1. Adjusting nut

EWA10650

## **⚠ WARNING**

**If proper adjustment cannot be obtained as described, have a Yamaha dealer make this adjustment.**

# PERIODIC MAINTENANCE AND MINOR REPAIR

EAU22170

## Adjusting the rear brake lever free play

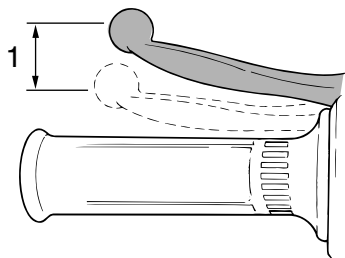

1. Rear brake lever free play

**6** The brake lever free play should measure 10 ~ 20 mm (0.4 ~ 0.8 in) as shown. Periodically check the brake lever free play and, if necessary, adjust it as follows.

To increase the brake lever free play, turn the adjusting nut at the brake shoe plate in direction (a). To decrease the brake lever free play, turn the adjusting nut in direction (b).

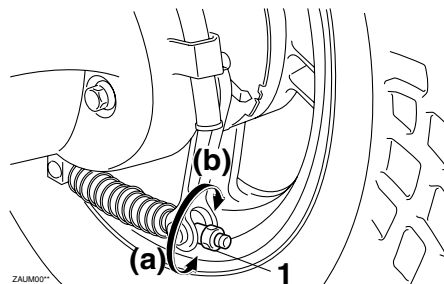

1. Adjusting nut

### **⚠ WARNING**

**If proper adjustment cannot be obtained as described, have a Yamaha dealer make this adjustment.**

EWA10650

EAU22361

## Checking the front and rear brake shoes

### Front

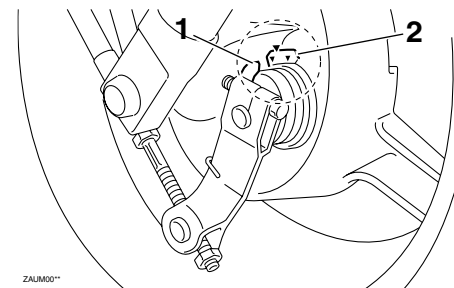

1. Wear indicator
2. Wear limit line

### Rear

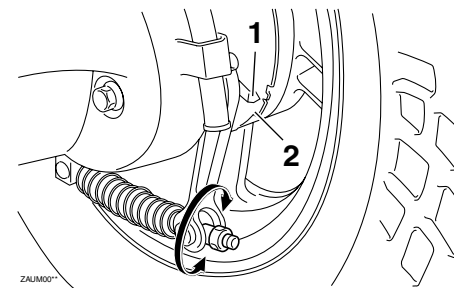

1. Wear indicator
2. Wear limit line



# PERIODIC MAINTENANCE AND MINOR REPAIR

The front and rear brake shoes must be checked for wear at the intervals specified in the periodic maintenance and lubrication chart. Each brake is provided with a wear indicator, which allows you to check the brake shoe wear without having to disassemble the brake. To check the brake shoe wear, check the position of the wear indicator while applying the brake. If a brake shoe has worn to the point that the wear indicator reaches the wear limit line, have a Yamaha dealer replace the brake shoes as a set.

EAU23111

## Checking and lubricating the throttle grip and cable

The operation of the throttle grip should be checked before each ride. In addition, the cable should be lubricated at the intervals specified in the periodic maintenance chart.

EAU43630

## Lubricating the front and rear brake levers

The pivoting points of the front and rear brake levers must be lubricated at the intervals specified in the periodic maintenance and lubrication chart.

### **Recommended lubricant:**

Lithium-soap-based grease (all-purpose grease)

# PERIODIC MAINTENANCE AND MINOR REPAIR

EAU23191

## Checking and lubricating the centerstand

The operation of the centerstand should be checked before each ride, and the pivots and metal-to-metal contact surfaces should be lubricated if necessary.

EWA11300

### **⚠ WARNING**

If the centerstand does not move up and down smoothly, have a Yamaha dealer check or repair it.

#### Recommended lubricant:

Lithium-soap-based grease (all-purpose grease)

EAU23271

## Checking the front fork

The condition and operation of the front fork must be checked as follows at the intervals specified in the periodic maintenance and lubrication chart.

### To check the condition

EWA10750

### **⚠ WARNING**

Securely support the motorcycle so that there is no danger of it falling over.

Check the inner tubes for scratches, damage and excessive oil leakage.

### To check the operation

1. Place the motorcycle on a level surface and hold it in an upright position.
2. While applying the front brake, push down hard on the handlebars several times to check if the front fork compresses and rebounds smoothly.

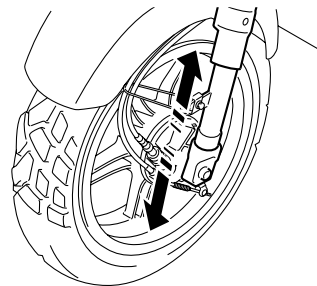

ZALM00\*

ECA10590

### **CAUTION:**

If any damage is found or the front fork does not operate smoothly, have a Yamaha dealer check or repair it.

EAU23280

## Checking the steering

Worn or loose steering bearings may cause danger. Therefore, the operation of the steering must be checked as follows at the intervals specified in the periodic maintenance and lubrication chart.

1. Place a stand under the engine to raise the front wheel off the ground.

EWA10750

### **⚠ WARNING**

**Securely support the motorcycle so that there is no danger of it falling over.**

2. Hold the lower ends of the front fork legs and try to move them forward and backward. If any free play can be felt, have a Yamaha dealer check or repair the steering.

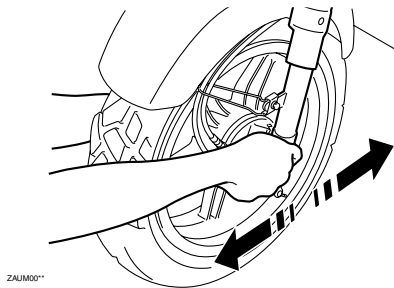

EAU23290

## Checking the wheel bearings

The front and rear wheel bearings must be checked at the intervals specified in the periodic maintenance and lubrication chart. If there is play in the wheel hub or if the wheel does not turn smoothly, have a Yamaha dealer check the wheel bearings.

# PERIODIC MAINTENANCE AND MINOR REPAIR

## Battery

EAUT1853

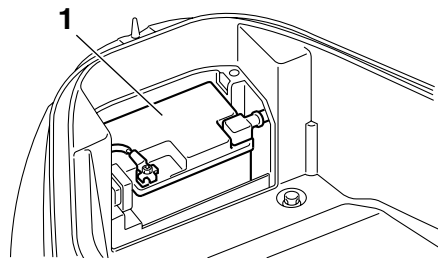

ZALN002\*

### 1. Battery

This model is equipped with a sealed-type (MF) battery, which does not require any maintenance. There is no need to check the electrolyte or to add distilled water.

#### NOTE:

The battery is located behind panel C. (See page 6-6.)

EWA10760

#### **⚠ WARNING**

- Electrolyte is poisonous and

dangerous since it contains sulfuric acid, which causes severe burns. Avoid any contact with skin, eyes or clothing and always shield your eyes when working near batteries. In case of contact, administer the following **FIRST AID**.

- **EXTERNAL:** Flush with plenty of water.
- **INTERNAL:** Drink large quantities of water or milk and immediately call a physician.
- **EYES:** Flush with water for 15 minutes and seek prompt medical attention.
- **Batteries produce explosive hydrogen gas. Therefore, keep sparks, flames, cigarettes, etc., away from the battery and provide sufficient ventilation when charging it in an enclosed space.**
- **KEEP THIS AND ALL BATTERIES OUT OF THE REACH OF CHILDREN.**

### To charge the battery

Have a Yamaha dealer charge the battery as soon as possible if it seems to have discharged. Keep in mind that the battery tends to discharge more quickly if the vehicle is equipped with optional electrical accessories.

### To store the battery

1. If the vehicle will not be used for more than one month, remove the battery, fully charge it, and then place it in a cool, dry place.
2. If the battery will be stored for more than two months, check it at least once a month and fully charge it if necessary.
3. Fully charge the battery before installation.
4. Before installation, make sure that the battery leads are properly connected to the battery terminals.

ECAT1051

#### **CAUTION:**

- Always keep the battery charged. Storing a discharged battery can cause permanent battery damage.

# PERIODIC MAINTENANCE AND MINOR REPAIR

- To charge a sealed-type (MF) battery, a special (constant-voltage) battery charger is required. Using a conventional battery charger will damage the battery. If you do not have access to a sealed-type (MF) battery charger, have a Yamaha dealer charge your battery.
- After installing the battery, be sure to turn the main switch from “ON” to “OFF” three times in 3 seconds intervals to initialize the idle speed control system.

## Replacing the fuse

EAUT2021

ECAT1061

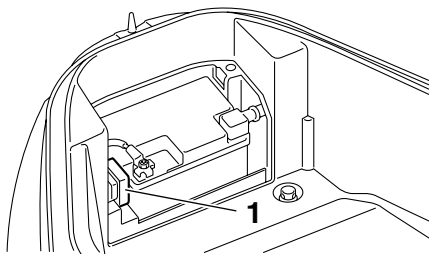

1. Fuse

The fuse holder is located beside the battery. Remove panel C to access the fuse. (See page 6-6.)

If the fuse is blown, replace it as follows.

1. Turn the key to “OFF” and turn off all electrical circuits.
2. Remove the blown fuse, and then install a new fuse of the specified amperage.

### Specified fuse:

15 A

### CAUTION:

- Do not use a fuse of a higher amperage rating than recommended to avoid causing extensive damage to the electrical system and possibly a fire.
- After removing and installing the main fuse, be sure to turn the main switch from “ON” to “OFF” three times in 3 seconds intervals to initialize the idle speed control system.

3. Turn the key to “ON” and turn on the electrical circuits to check if the devices operate.
4. If the fuse immediately blows again, have a Yamaha dealer check the electrical system.

# PERIODIC MAINTENANCE AND MINOR REPAIR

EAU23780

## Replacing the headlight bulb

This model is equipped with a quartz bulb headlight. If the headlight bulb burns out, replace it as follows.

1. Remove the headlight unit by removing the screws.

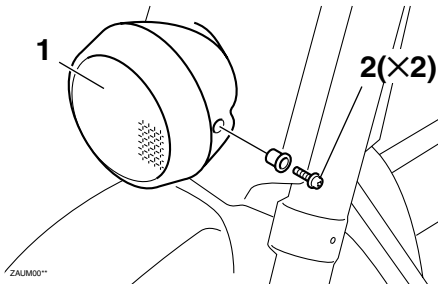

1. Headlight unit
2. Screw

2. Disconnect the headlight coupler, and then remove the bulb cover.

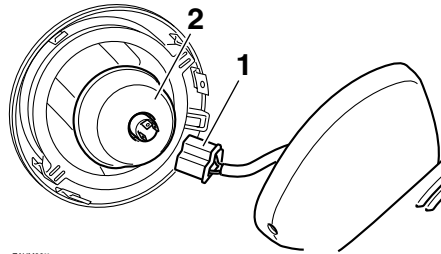

ZALUM00\*

1. Headlight coupler
2. Bulb cover

3. Remove the headlight bulb holder by turning it counterclockwise, and then remove the defective bulb.

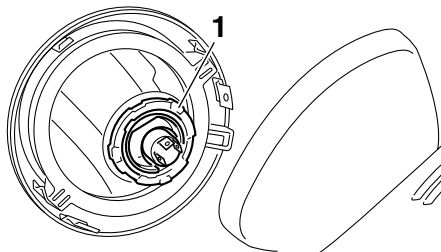

ZALUM00\*

1. Headlight bulb holder

EWA10790

## **WARNING**

Headlight bulbs get very hot. Therefore, keep flammable products away from a lit headlight bulb, and do not touch the bulb until it has cooled down.

4. Place a new headlight bulb into position, and then secure it with the bulb holder.

ECA10660

## **CAUTION:**

Do not touch the glass part of the headlight bulb to keep it free from oil, otherwise the transparency of the glass, the luminosity of the bulb, and the bulb life will be adversely affected. Thoroughly clean off any dirt and fingerprints on the headlight bulb using a cloth moistened with alcohol or thinner.

5. Install the headlight bulb cover, and then connect the coupler.
6. Install the headlight unit by installing the screws.

# PERIODIC MAINTENANCE AND MINOR REPAIR

7. Have a Yamaha dealer adjust the headlight beam if necessary.

## Replacing the tail/brake light bulb EAU24131

otherwise the lens may break.

1. Remove the tail/brake light lens by removing the screws.

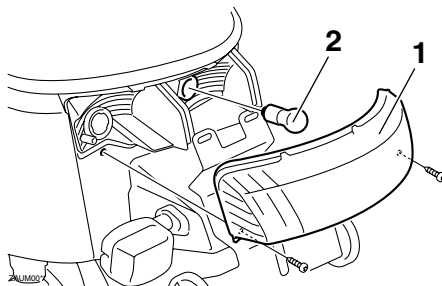

1. Tail/brake light lens
2. Bulb

2. Remove the defective bulb by pushing it in and turning it counter-clockwise.
3. Insert a new bulb into the socket, push it in, and then turn it clockwise until it stops.
4. Install the lens by installing the screws.

ECA10680

### **CAUTION:**

**Do not overtighten the screws, oth-**

# PERIODIC MAINTENANCE AND MINOR REPAIR

EAU24202

## Replacing a turn signal light bulb

1. Remove the turn signal light lens by removing the screw.

### Front

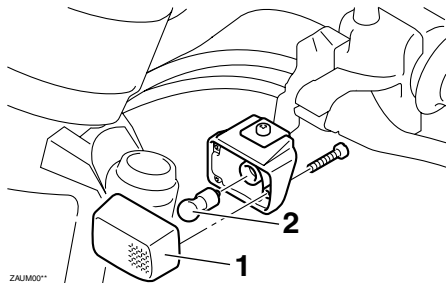

1. Turn signal light lens
2. Bulb

### Rear

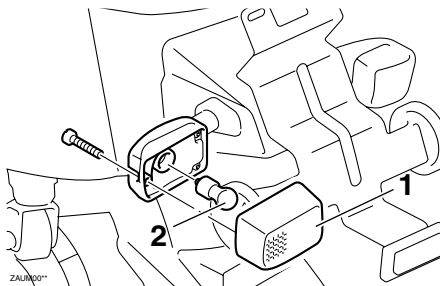

1. Turn signal light lens
2. Bulb
2. Remove the defective bulb by pushing it in and turning it counter-clockwise.
3. Insert a new bulb into the socket, push it in, and then turn it clockwise until it stops.
4. Install the lens by installing the screw.

ECA11190

### CAUTION:

**Do not overtighten the screw, otherwise the lens may break.**

EAU25880

## Troubleshooting

Although Yamaha scooters receive a thorough inspection before shipment from the factory, trouble may occur during operation. Any problem in the fuel, compression, or ignition systems, for example, can cause poor starting and loss of power.

The following troubleshooting charts represent quick and easy procedures for checking these vital systems yourself. However, should your scooter require any repair, take it to a Yamaha dealer, whose skilled technicians have the necessary tools, experience, and know-how to service the scooter properly.

Use only genuine Yamaha replacement parts. Imitation parts may look like Yamaha parts, but they are often inferior, have a shorter service life and can lead to expensive repair bills.



# PERIODIC MAINTENANCE AND MINOR REPAIR

EUA42700

## Troubleshooting charts

### Starting problems or poor engine performance

EWA10840

#### **⚠ WARNING**

Keep away open flames and do not smoke while checking or working on the fuel system.

#### 1. Fuel

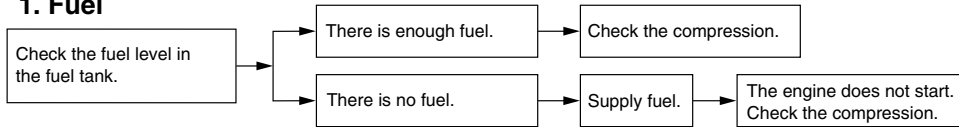

#### 2. Compression

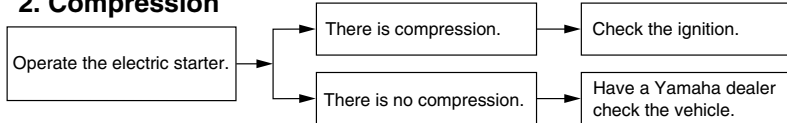

#### 3. Ignition

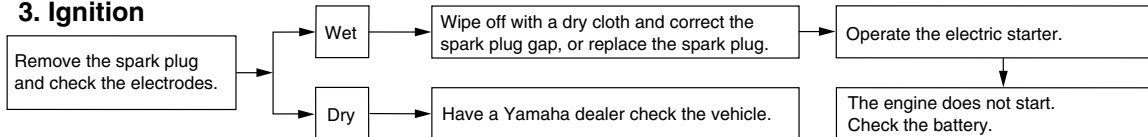

#### 4. Battery

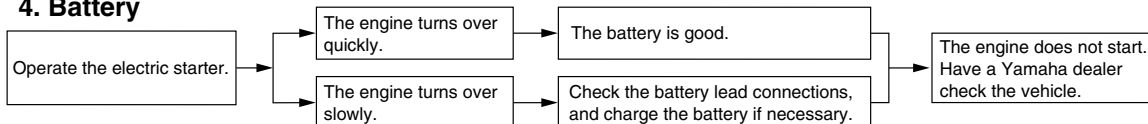

# PERIODIC MAINTENANCE AND MINOR REPAIR

## Engine overheating

EWAT1040

### **⚠ WARNING**

- Do not remove the radiator cap when the engine and radiator are hot. Scalding hot fluid and steam may be blown out under pressure, which could cause serious injury. Be sure to wait until the engine has cooled.
- Place a thick rag, like a towel, over the radiator cap, and then slowly rotate the cap counterclockwise to the detent to allow any residual pressure to escape. When the hissing sound has stopped, press down on the cap while turning it counterclockwise, and then remove the cap.

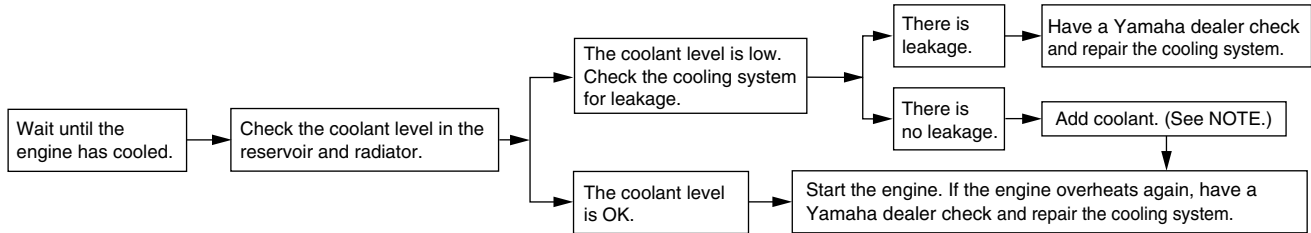

### **NOTE:**

If coolant is not available, tap water can be temporarily used instead, provided that it is changed to the recommended coolant as soon as possible.

## Care

While the open design of a scooter reveals the attractiveness of the technology, it also makes it more vulnerable. Rust and corrosion can develop even if high-quality components are used. A rusty exhaust pipe may go unnoticed on a car, however, it detracts from the overall appearance of a scooter. Frequent and proper care does not only comply with the terms of the warranty, but it will also keep your scooter looking good, extend its life and optimize its performance.

### Before cleaning

1. Cover the muffler outlet with a plastic bag after the engine has cooled down.
2. Make sure that all caps and covers as well as all electrical couplers and connectors, including the spark plug cap, are tightly installed.
3. Remove extremely stubborn dirt, like oil burnt onto the crankcase, with a degreasing agent and a brush, but never apply such products onto seals, gaskets and wheel

EAU26091

axles. Always rinse the dirt and degreaser off with water.

### Cleaning

ECA10781

#### **CAUTION:**

- **Avoid using strong acidic wheel cleaners, especially on spoked wheels. If such products are used on hard-to-remove dirt, do not leave the cleaner on the affected area any longer than instructed. Also, thoroughly rinse the area off with water, immediately dry it, and then apply a corrosion protection spray.**
- **Improper cleaning can damage plastic parts such as cowlings, panels, windshields, headlight lenses, meter lenses, etc. Use only a soft, clean cloth or sponge with mild detergent and water to clean plastic.**
- **Do not use any harsh chemical products on plastic parts. Be sure to avoid using cloths or sponges which have been in contact with strong or abrasive cleaning products, solvent or**

thinner, fuel (gasoline), rust removers or inhibitors, brake fluid, antifreeze or electrolyte.

- **Do not use high-pressure washers or steam-jet cleaners since they cause water seepage and deterioration in the following areas: seals (of wheel and swingarm bearings, fork and brakes), electric components (couplers, connectors, instruments, switches and lights), breather hoses and vents.**
- **For scooters equipped with a windshield: Do not use strong cleaners or hard sponges as they will cause dulling or scratching. Some cleaning compounds for plastic may leave scratches on the windshield. Test the product on a small hidden part of the windshield to make sure that it does not leave any marks. If the windshield is scratched, use a quality plastic polishing compound after washing.**

# SCOOTER CARE AND STORAGE

---

## After normal use

Remove dirt with warm water, a mild detergent, and a soft, clean sponge, and then rinse thoroughly with clean water. Use a toothbrush or bottlebrush for hard-to-reach areas. Stubborn dirt and insects will come off more easily if the area is covered with a wet cloth for a few minutes before cleaning.

## After riding in the rain, near the sea or on salt-sprayed roads

Since sea salt or salt sprayed on the roads during winter are extremely corrosive in combination with water, carry out the following steps after each ride in the rain, near the sea or on salt-sprayed roads.

### NOTE:

Salt sprayed on roads in the winter may remain well into spring.

1. Clean the scooter with cold water and a mild detergent after the engine has cooled down.

ECA10790

### CAUTION:

**Do not use warm water since it increases the corrosive action of the salt.**

2. Apply a corrosion protection spray on all metal, including chrome- and nickel-plated, surfaces to prevent corrosion.

## After cleaning

1. Dry the scooter with a chamois or an absorbing cloth.
2. Use a chrome polish to shine chrome, aluminum and stainless-steel parts, including the exhaust system. (Even the thermally induced discoloring of stainless-steel exhaust systems can be removed through polishing.)
3. To prevent corrosion, it is recommended to apply a corrosion protection spray on all metal, including chrome- and nickel-plated, surfaces.
4. Use spray oil as a universal cleaner to remove any remaining dirt.

5. Touch up minor paint damage caused by stones, etc.
6. Wax all painted surfaces.
7. Let the scooter dry completely before storing or covering it.

EWA10940

### WARNING

- **Make sure that there is no oil or wax on the brakes or tires. If necessary, clean the brake discs and brake linings with a regular brake disc cleaner or acetone, and wash the tires with warm water and a mild detergent.**
- **Before operating the scooter test its braking performance and cornering behavior.**

ECA10800

### CAUTION:

- **Apply spray oil and wax sparingly and make sure to wipe off any excess.**
- **Never apply oil or wax to any rubber and plastic parts, but treat them with a suitable care product.**
- **Avoid using abrasive polishing compounds as they will wear**

# SCOOTER CARE AND STORAGE

away the paint.

**NOTE:** \_\_\_\_\_  
Consult a Yamaha dealer for advice on what products to use.

EAU36560

## Storage

### Short-term

Always store your scooter in a cool, dry place and, if necessary, protect it against dust with a porous cover.

ECA10820

### CAUTION:

- **Storing the scooter in a poorly ventilated room or covering it with a tarp, while it is still wet, will allow water and humidity to seep in and cause rust.**
- **To prevent corrosion, avoid damp cellars, stables (because of the presence of ammonia) and areas where strong chemicals are stored.**

### Long-term

Before storing your scooter for several months:

1. Follow all the instructions in the “Care” section of this chapter.
2. Fill up the fuel tank and add fuel stabilizer (if available) to prevent the fuel tank from rusting and the fuel from deteriorating.

3. Perform the following steps to protect the cylinder, piston rings, etc. from corrosion.
  - a. Remove the spark plug cap and spark plug.
  - b. Pour a teaspoonful of engine oil into the spark plug bore.
  - c. Install the spark plug cap onto the spark plug, and then place the spark plug on the cylinder head so that the electrodes are grounded. (This will limit sparking during the next step.)
  - d. Turn the engine over several times with the starter. (This will coat the cylinder wall with oil.)
  - e. Remove the spark plug cap from the spark plug, and then install the spark plug and the spark plug cap.

EWA10950

### **⚠ WARNING**

**To prevent damage or injury from sparking, make sure to ground the spark plug electrodes while turning the engine over.**

# SCOOTER CARE AND STORAGE

---

4. Lubricate all control cables and the pivoting points of all levers and pedals as well as of the sidestand/centerstand.
5. Check and, if necessary, correct the tire air pressure, and then lift the scooter so that both of its wheels are off the ground. Alternatively, turn the wheels a little every month in order to prevent the tires from becoming degraded in one spot.
6. Cover the muffler outlet with a plastic bag to prevent moisture from entering it.
7. Remove the battery and fully charge it. Store it in a cool, dry place and charge it once a month. Do not store the battery in an excessively cold or warm place [less than 0 °C (30 °F) or more than 30 °C (90 °F)]. For more information on storing the battery, see page 6-20.

**NOTE:** \_\_\_\_\_

Make any necessary repairs before storing the scooter.

---

## Dimensions

Overall length	1915 mm (75.4 in)
Overall width	695 mm (27.4 in)
Overall height	1040 mm (40.9 in)
Seat height	750 mm (29.5 in)
Wheelbase	1280 mm (50.4 in)
Ground clearance	115 mm (4.53 in)
Minimum turning radius	2000 mm (78.7 in)

## Weight

With oil and fuel	93.0 kg (205 lb)
-------------------	------------------

## Engine

Engine type	Liquid cooled 4-stroke, SOHC
Cylinder arrangement	Forward-inclined single cylinder
Displacement	49.0 cm <sup>3</sup>
Bore x stroke	38.0 x 43.6 mm (1.50 x 1.72 in)
Compression ratio	12.00 :1
Starting system	Electric starter and kickstarter
Lubrication system	Wet sump

## Engine oil

Type  
SAE10W40

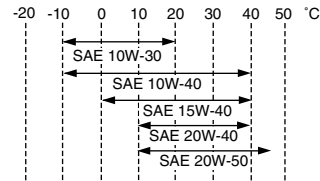

Recommended engine oil grade  
API service SG type or higher, JASO  
standard MA  
Periodic oil change  
0.78 L (0.82 US qt) (0.69 Imp.qt)

## Final transmission oil

Type  
SAE10W30 type SE motor oil  
Quantity  
0.10 L (0.11 US qt) (0.09 Imp.qt)

## Cooling system

Coolant reservoir capacity (up to the maximum level mark)  
0.26 L (0.27 US qt) (0.23 Imp.qt)  
Radiator capacity (including all routes)  
0.50 L (0.53 US qt) (0.44 Imp.qt)

## Air filter

Air filter element  
Wet element"

## Fuel

Recommended fuel  
Regular unleaded gasoline only

Fuel tank capacity  
4.5 L (1.19 US gal) (0.99 Imp.gal)

## Throttle body

Type/quantity  
3B31 00(SE AC19-1) / 1  
Manufacturer  
MIKUNI"

## Spark plug (s)

Manufacturer/model  
NGK/CR7E  
Spark plug gap  
0.7-0.8 mm (0.028-0.031 in)

## Clutch

Clutch type  
Dry, centrifugal automatic

## Transmission

Primary reduction system  
Helical gear  
Primary reduction ratio  
50/13 (3.846)  
Secondary reduction system  
Helical gear  
Secondary reduction ratio  
43/12 (3.583)  
Transmission type  
V-belt automatic  
Operation  
Centrifugal automatic type

## Chassis

Frame type  
Steel tube backbone  
Caster angle  
26.00 degree

# SPECIFICATIONS

Trail  
84.0 mm (3.31 in)

## Front tire

Type  
Tubeless  
Size  
120/90-10 57J  
Manufacturer/model  
CHENG SHIN / C-6022

## Rear tire

Type  
Tubeless  
Size  
120/90-10 57J  
Manufacturer/model  
CHENG SHIN / C-6022  
Maximum load  
177 kg (390 lb)

## Tire air pressure (measured on cold tires)

Front  
175 kPa (25 psi) (1.75 kgf/cm<sup>2</sup>) (1.75 bar)  
Rear  
175 kPa (25 psi) (1.75 kgf/cm<sup>2</sup>) (1.75 bar)

## Front wheel

Wheel type  
Cast wheel  
Rim size  
10 x 3.00

## Rear wheel

Wheel type  
Cast wheel  
Rim size  
10 x 3.00

## Front brake

Type  
Drum brake  
Operation  
Right hand operation

## Rear brake

Type  
Drum brake  
Operation  
Left hand operation

## Front suspension

Type  
Telescopic fork  
Spring/shock absorber type  
Coil spring  
Wheel travel  
65.0 mm (2.56 in)

## Rear suspension

Type  
Unit swing  
Spring/shock absorber type  
Coil spring  
Wheel travel  
56.0 mm (2.20 in)

## Electrical system

Ignition system  
Transistorized coil ignition  
Charging system  
AC magneto

## Battery

Model  
GTX5L-BS

Voltage, capacity  
12 V, 4.0 Ah

## Headlight

Bulb type  
Halogen bulb

## Bulb voltage, wattage x quantity

Headlight  
12 V, 35 W/35.0 W x 1  
Tail/brake light  
12 V, 5.0 W/21.0 W x 1  
Front turn signal light  
12 V, 10.0 W x 2  
Rear turn signal light  
12 V, 10.0 W x 2  
License plate light (15P3/15P4)  
12 V, 5.0 W x 1  
Meter lighting  
12 V, 1.7 W x 1  
High beam indicator light  
12 V, 1.7 W x 1  
Turn signal indicator light  
14 V, 3.0 W x 1  
Coolant temperature warning light  
12 V, 1.7 W x 1  
Engine trouble warning light  
12 V, 1.7 W x 1

## Fuses

Main fuse  
15.0 A



EAU26351

## Identification numbers

Record the key identification number, vehicle identification number and model label information in the spaces provided below for assistance when ordering spare parts from a Yamaha dealer or for reference in case the vehicle is stolen.

KEY IDENTIFICATION NUMBER:

VEHICLE IDENTIFICATION NUMBER:

MODEL LABEL INFORMATION:

## Key identification number

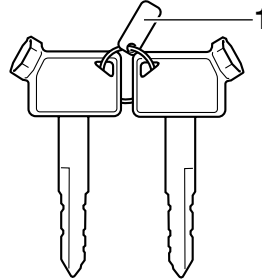

ZAJM00\*

1. Key identification number

The key identification number is stamped into the key tag. Record this number in the space provided and use it for reference when ordering a new key.

EAU26381

## Vehicle identification number

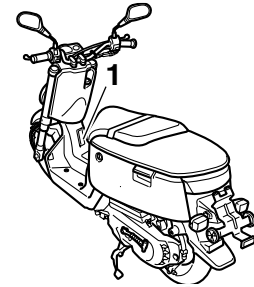

ZAJM00\*

1. Vehicle identification number

The vehicle identification number is stamped into the frame.

**NOTE:** \_\_\_\_\_  
The vehicle identification number is used to identify your motorcycle and may be used to register your motorcycle with the licensing authority in your area.  
\_\_\_\_\_

# CONSUMER INFORMATION

---

EAUT1440

## Model label

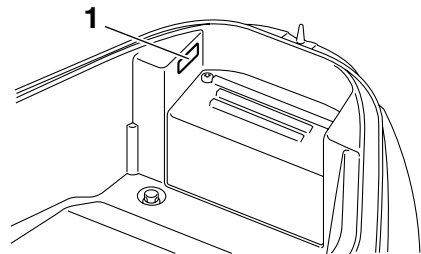

ZALUM00\*

### 1. Model label

The model label is affixed to the inside of the storage compartment. (See page 3-10.) Record the information on this label in the space provided. This information will be needed when ordering spare parts from a Yamaha dealer.

<b>A</b>	Acceleration and deceleration .....	5-2	High beam indicator light .....	3-3	Steering, checking .....	6-19		
	Air filter element, replacing .....	6-12	Horn switch .....	3-5	Storage .....	7-3		
<b>B</b>			<b>I</b>	Identification numbers .....	9-1	Storage compartment .....	3-10	
	Battery .....	6-20		Indicator and warning lights .....	3-2	<b>T</b>	Tail/brake light bulb, replacing .....	6-23
	Brake lever free play, adjusting .....	6-15	<b>K</b>				Throttle cable free play, checking .....	6-12
	Brake lever, front .....	3-6		Key identification number .....	9-1		Throttle grip and cable, checking and lubricating .....	6-17
	Brake lever, rear .....	3-6		Keyhole cover .....	3-2		Tires .....	6-13
	Brake levers, lubricating .....	6-17		Kickstarter .....	3-8		Troubleshooting .....	6-24
	Brake shoes, checking .....	6-16	<b>L</b>				Troubleshooting charts .....	6-25
	Braking .....	5-2		Luggage hook .....	3-9		Turn signal indicator light .....	3-3
<b>C</b>			<b>M</b>				Turn signal light bulb, replacing .....	6-24
	Care .....	7-1		Main switch/steering lock .....	3-1		Turn signal switch .....	3-5
	Catalytic converter .....	3-8		Maintenance, periodic .....	6-1	<b>V</b>		
	Centerstand, checking and lubricating ..	6-18		Model label .....	9-2		Valve clearance .....	6-12
	Coolant .....	6-10	<b>P</b>				Vehicle identification number .....	9-1
	Coolant temperature warning light .....	3-3		Panels, removing and installing .....	6-5	<b>W</b>		
<b>D</b>				Parking .....	5-3		Wheel bearings, checking .....	6-19
	Dimmer switch .....	3-5		Part locations .....	2-1		Wheels .....	6-15
<b>E</b>				Periodic maintenance and lubrication chart .....	6-2			
	Engine break-in .....	5-3		Pre-operation check list .....	4-2			
	Engine oil .....	6-7	<b>R</b>					
	Engine trouble warning light .....	3-3		Rear brake lever free play, adjusting .....	6-16			
<b>F</b>			<b>S</b>					
	Final transmission oil .....	6-9		Safe-riding points .....	1-4			
	Front fork, checking .....	6-18		Safety information .....	1-1			
	Fuel .....	3-7		Seat .....	3-9			
	Fuel gauge .....	3-4		Spark plug, checking .....	6-6			
	Fuel tank cap .....	3-6		Specifications .....	8-1			
	Fuse, replacing .....	6-21		Speedometer unit .....	3-4			
<b>H</b>				Start switch .....	3-5			
	Handlebar switches .....	3-5		Starting off .....	5-2			
	Headlight bulb, replacing .....	6-22		Starting the engine .....	5-1			
	Helmet holder .....	3-9						

# INDEX

---

---









